

# **SINGER**

## **6100 Series**

173745-072

62-33 01-

**SINGER**

SINGER FACTORY

-MONZA-

**List of Parts**

**Sewing Machines Series**

**6100**

\* Copyright © 1983 THE SINGER COMPANY  
All Rights Reserved Throughout the World

\* A Trademark of THE SINGER COMPANY

From the library of: Diamond Needle Corp

# contents

MECHANISM GROUP NO.		PAGE
1	TOP, BACK and SIDES COVERS .....	4
	FRONT COVER .....	6, 8, 10
	MACHINE BASE and CLOTH PLATE .....	12
2	NEEDLE BAR and DRIVE MECHANISM .....	14
	NEEDLE HOOK and PLATES .....	16
	PRESSURE BAR and TENSION .....	18
3	FEED and HOOK DRIVE MECHANISM (Tubular Bed) .....	20
	FEED and HOOK DRIVE MECHANISM (Flat Bed) .....	22
4	STITCH LENGTH and REVERSE MECHANISM .....	24
	BUTTONHOLER, FEED REGULATOR and CAM CONTROL .....	
	FEED ENGAGING MECHANISM .....	26
	CAM CONTROL FEED and STITCH BALANCING MECHANISM .....	28
5	BIGHT AMPLITUDE and NEEDLE POSITION SELECTORS .....	30
	CAM STACK and PATTERN SELECTOR .....	32
6	ATTACHMENTS .....	34
	MACHINE CARRYING CASE and BOTTOM COVER .....	36
7	ELECTRICS .....	38

## IMPORTANT:

The designations listed below must be applied throughout this manual as follow:

6106 for 6106-6116-6126-6136-6146-6156 models

6105 for 6105-6115-6125 models

6104 for 6104-6114-6124 models

6102 for 6102-6112-6122-6152 models

6100 for 6110-6120-6130 models

## SINGER

Stabilimento Macchine per Cucire

Viale Sicilla, 75

20052 MONZA (Italy)

Phone: (039) 839001-9

Telex: Pyecom 333301

Printed in Italy

# contents

Group

**1**

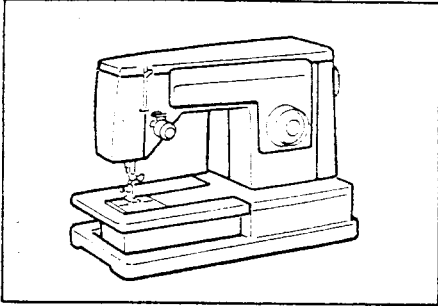

**2**

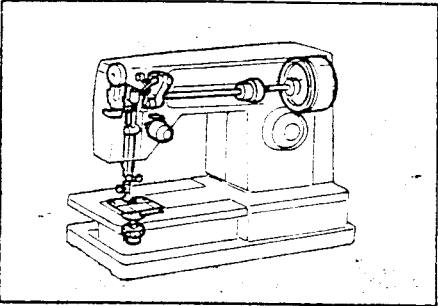

**3**

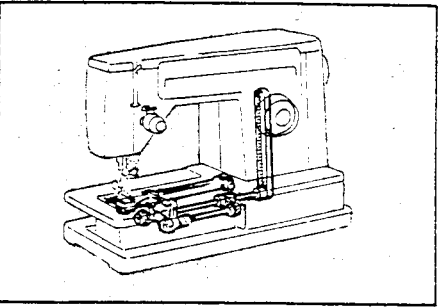

**3**

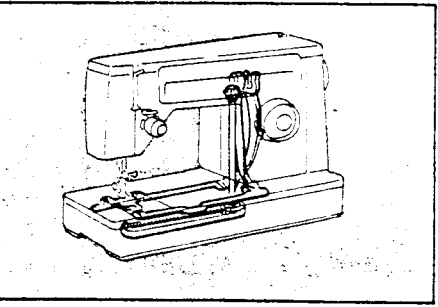

**4**

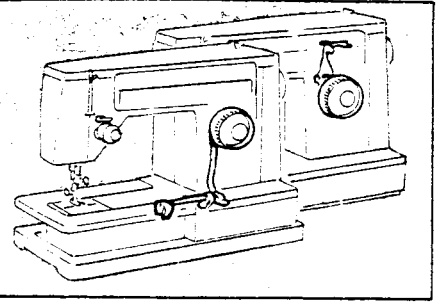

Group

**4**

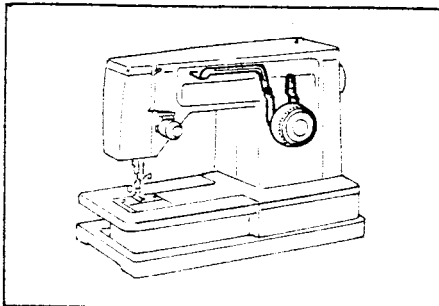

**4**

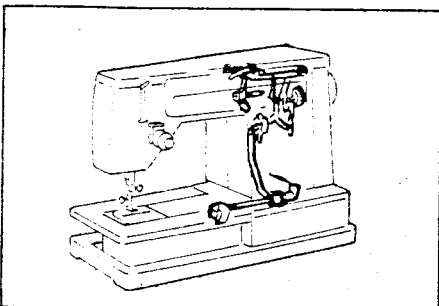

**5**

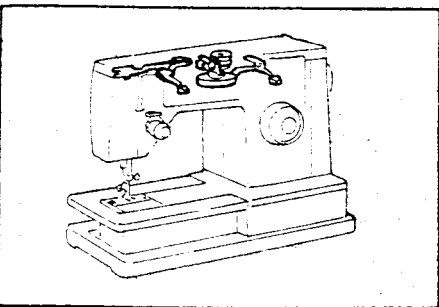

**6**

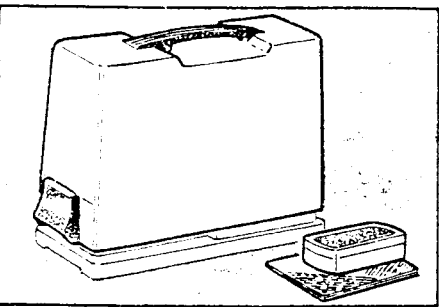

**7**

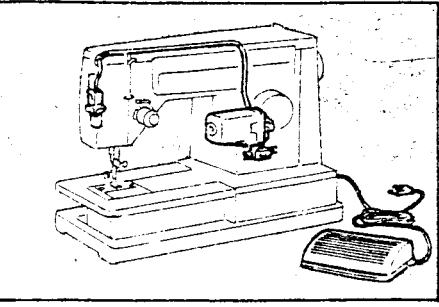

1

# 6100 series

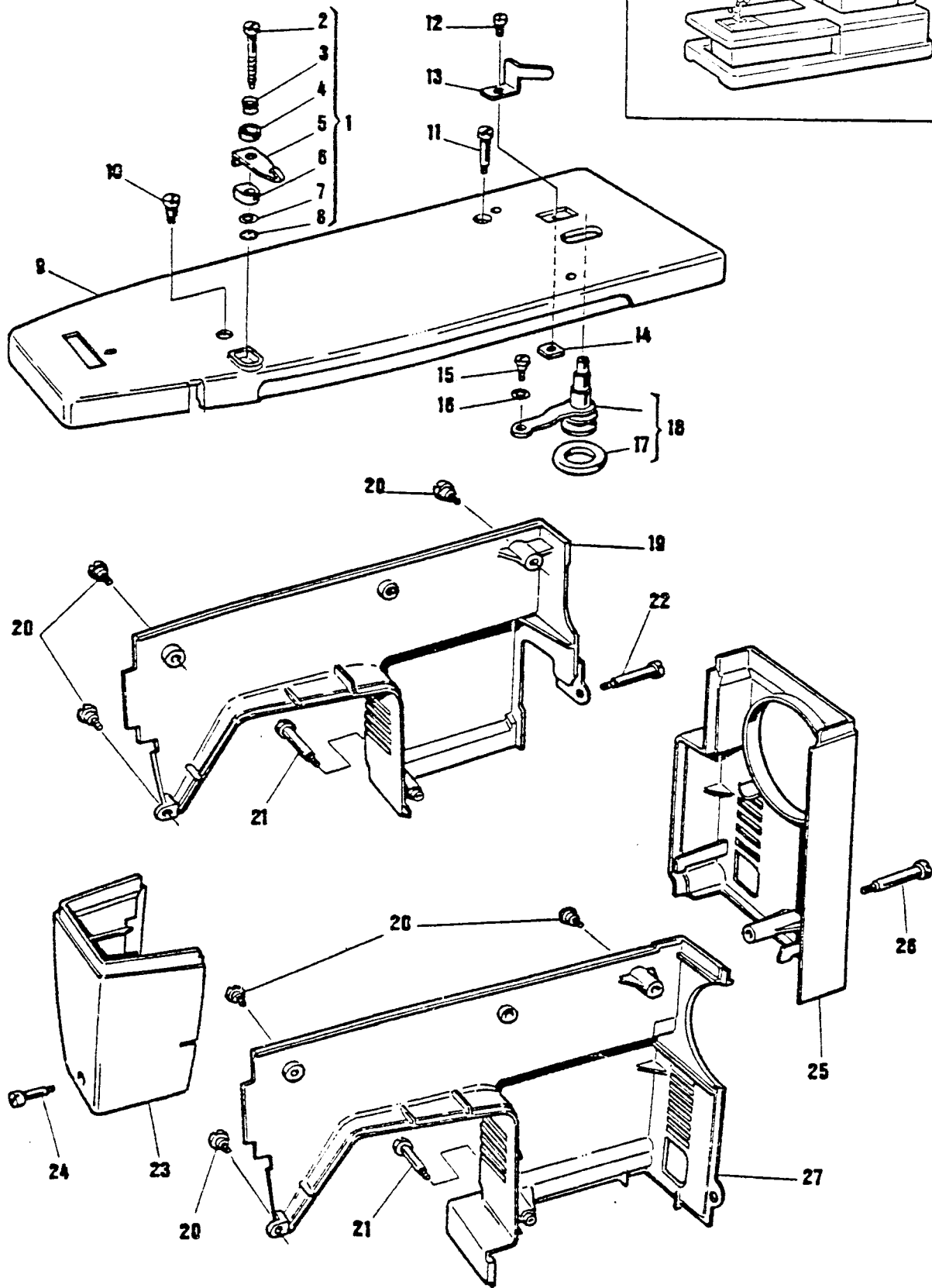
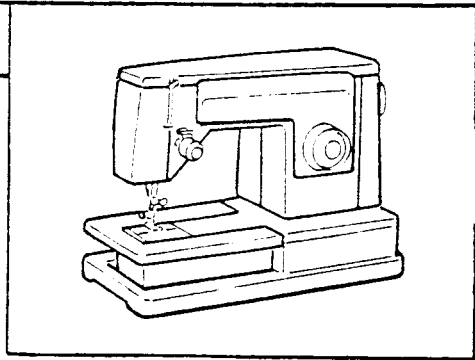

From the library of: Diamond Needle Corp

LIST OF PARTS FOR MACHINES 6100 SERIES

REF. N.	PART. N.	6174	6184	6100	6106	6105	6104	6102	PART DESCRIPTION
1	422069-451	X	X	X	X	X	X	X	Bobbin winder tension cpl.
2	44751	X	X	X	X	X	X	X	Bobbin winder tension stud
3	45847	X	X	X	X	X	X	X	Tension disc spring
4	45915	X	X	X	X	X	X	X	Tension disc
5	319717	X	X	X	X	X	X	X	Tension bracket and thread guide
6	44770-459	X	X	X	X	X	X	X	Tension bracket spacer
7	352737	X	X	X	X	X	X	X	Tension stud washer
8	44447	X	X	X	X	X	X	X	Tension stud retaining ring
9	421664-451	X	X	X	X	X	X	X	Arm top cover (with insert)
10	421720	X	X	X	X	X	X	X	Arm top cover screw (left)
11	141788	X	X	X	X	X	X	X	Arm top cover screw (right)
12	141808	X	X	X	X	X	X	X	Bobbin winder stop screw
13	44365	X	X	X	X	X	X	X	Bobbin winder stop
14	53640	X	X	X	X	X	X	X	Bobbin winder stop screw nut
15	422025-451	X	X	X	X	X	X	X	Hinge screw
16	352026	X	X	X	X	X	X	X	Hinge screw washer
17	15287-701	X	X	X	X	X	X	X	Friction ring
18	421960	X	X	X	X	X	X	X	Bobbin winder cpl.
19	421652-451	X							Arm cover (back)
20	139910	X	X	X	X	X	X	X	Arm cover (back) screw (3)
21	354252-451	X	X	X	X	X	X	X	Arm cover (back) screw
22	354659-451	X							Arm cover (back and front) screw
23	421653-451	X	X	X	X	X	X	X	Face plate
24	514727-451	X	X	X	X	X	X	X	Face plate screw
25	421654-451	X							Arm cover (hand wheel side)
26	354655-451	X							Arm cover (hand Wheel side) screw
27	422439-451		X	X	X	X	X	X	Arm cover (back)

*6115  
6126 6115  
6130 6125 6114  
6140  
6130*

From the library of: Diamond Needle Corp

1

# 6100 series

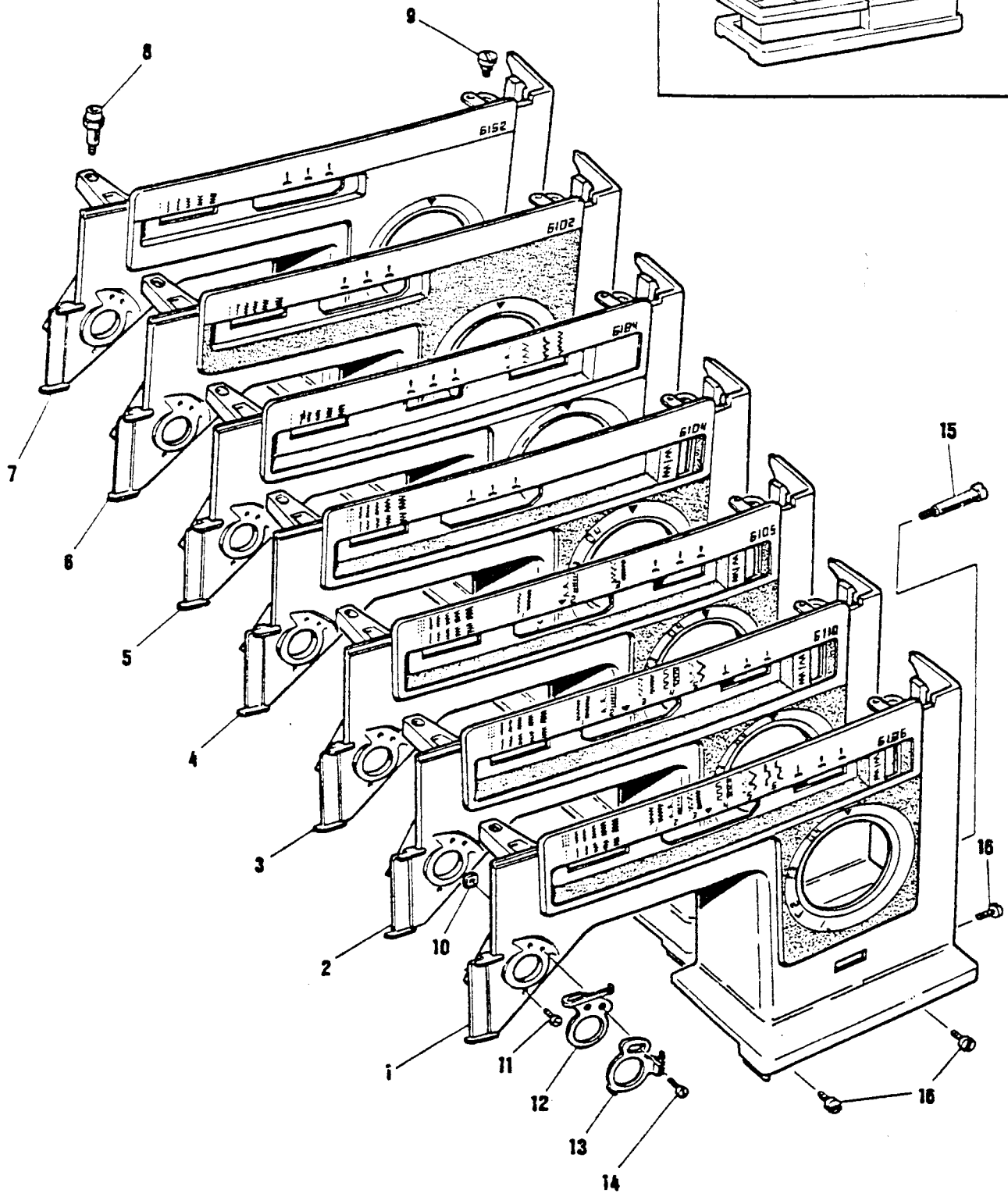
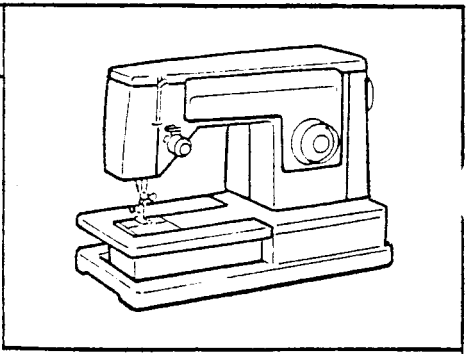

From the library of: Diamond Needle Corp

## LIST OF PARTS FOR MACHINES 6100 SERIES

REF. N.	PART. N.	6136	6106	6110	6105	6184	6104	6102	6152	PART DESCRIPTION
1	422444 ●●●		X							Arm front cover cpl.
	422445 ●●●	X								Arm front cover cpl.
	422466 ●●●	X								Arm front cover cpl. (USA only)
2	422465 ●●●			X						Arm front cover cpl.
	422465-452			X						Arm front cover cpl. (for model 6130 only)
3	422443 ●●●				X					Arm front cover cpl.
4	422442 ●●●						X			Arm front cover cpl.
5	422092 -451					X				Arm front cover cpl.
6	422446 ●●●							X		Arm front cover cpl.
7	422456-458								X	Arm front cover cpl.
8	421719-451	X	X	X	X	X	X	X	X	Arm front cover screw (upper, left)
9	421720	X	X	X	X	X	X	X	X	Arm front cover screw (upper, right)
10	53640	X	X	X	X	X	X	X	X	Nut
11	141808	X	X	X	X	X	X	X	X	Arm front cover screw (lower, left)
12	446958	X	X	X	X	X	X	X	X	Thread guide (upper)
13	44392	X	X	X	X	X	X	X	X	Tension thread guide
14	141808	X	X	X	X	X	X	X	X	Screw
15	422463-451	X	X	X	X	X	X	X	X	Arm cover (hand wheel side) screw
16	139910	X	X	X	X	X	X	X	X	Bed cover screw (3)

●●● Suffix 451 for M003 variety  
 Suffix 452 for M013 variety  
 Suffix 453 for M023 variety  
 Suffix 454 for M033 variety  
 Suffix 455 for M043 variety  
 Suffix 456 for M053 variety



1

# 6100 series

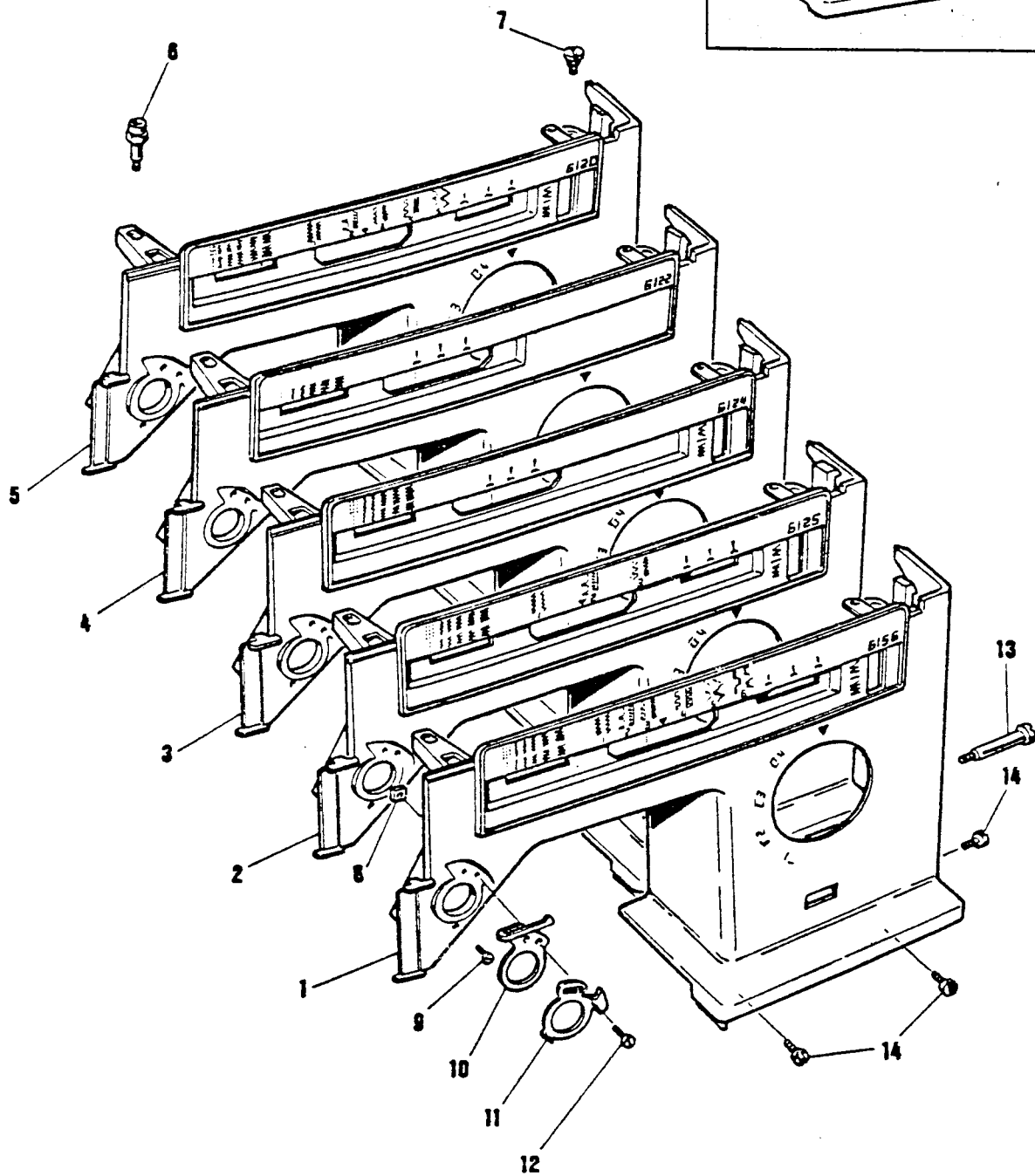
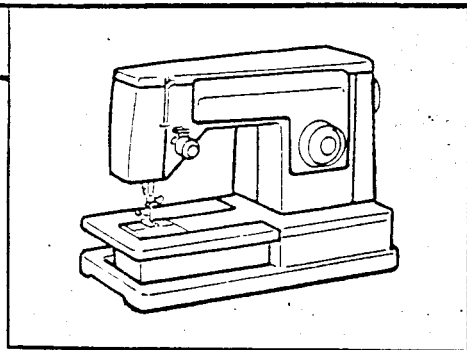

From the library of: Diamond Needle Corp

LIST OF PARTS FOR MACHINES 6100 SERIES

REF. N.	PART. N.	6126	6156	6125	6124	6122	6120		PART DESCRIPTION
1	422455 ●●●		X						Arm front cover cpl.
	422454 ●●●	X							Arm front cover cpl.
2	422453 ●●●			X					Arm front cover cpl.
3	422452 ●●●				X				Arm front cover cpl.
4	422456 ●●●					X			Arm front cover cpl.
5	422263-451						X		Arm front cover cpl.
6	421719-451	X	X	X	X	X	X		Arm front cover screw (upper , left)
7	421720	X	X	X	X	X	X		Arm front cover screw (upper, right)
8	53640	X	X	X	X	X	X		Nut
9	141808	X	X	X	X	X	X		Arm front cover screw (lower , left)
10	446958	X	X	X	X	X	X		Thread guide (upper)
11	44392	X	X	X	X	X	X		Tension thread guide
12	141808	X	X	X	X	X	X		Screw
13	422463-451	X	X	X	X	X	X		Arm cover (hand wheel side) screw
14	139910	X	X	X	X	X	X		Bed cover screw (3)

●●● Suffix 451 for M003 variety  
 Suffix 452 for M013 variety  
 Suffix 453 for M023 variety  
 Suffix 454 for M033 variety  
 Suffix 455 for M043 variety  
 Suffix 456 for M053 variety

1

# 6100 series

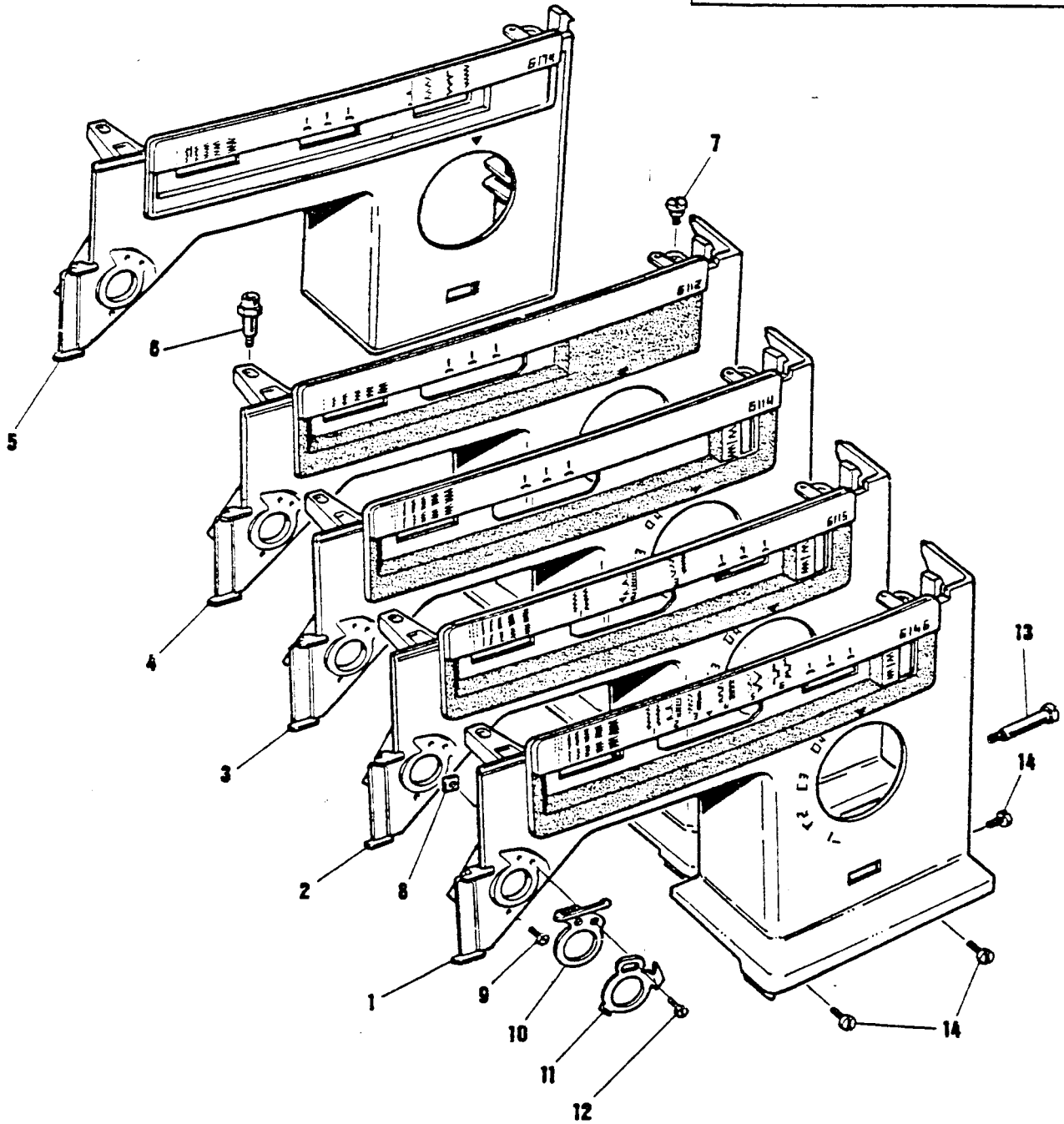
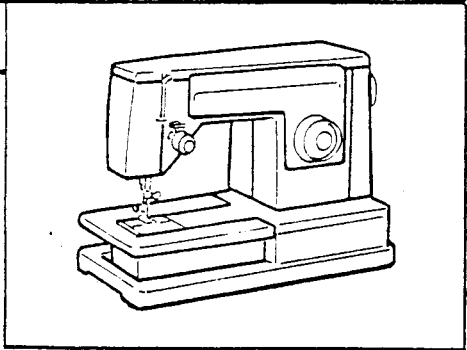

From the library of: Diamond Needle Corp

LIST OF PARTS FOR MACHINES 6100 SERIES

REF. N.	PART. N.	6174	6146	6115	6114	6112				PART DESCRIPTION
1	422450 ●●●		X							Arm front cover cpl.
	422449 ●●●		X							Arm front cover cpl. (USA only)
2	422448 ●●●			X						Arm front cover cpl.
3	422447 ●●●				X					Arm front cover cpl.
4	422451 ●●●					X				Arm front cover cpl.
5	422259-451	X								Arm front cover cpl.
6	421719-451	X	X	X	X	X				Arm front cover screw (upper, left)
7	421720	X	X	X	X	X				Arm front cover screw (upper, right)
8	53640	X	X	X	X	X				Nut
9	141808	X	X	X	X	X				Arm front cover screw (lower, left)
10	446958	X	X	X	X	X				Thread guide (upper)
11	44392	X	X	X	X	X				Tension thread guide
12	141808	X	X	X	X	X				Screw
13	422463-451		X	X	X	X				Arm cover (hand wheel side) screw
14	139910		X	X	X	X				Bed cover screw (3)

●●● Suffix 451 for M003 variety  
 Suffix 452 for M013 variety  
 Suffix 453 for M023 variety  
 Suffix 454 for M033 variety  
 Suffix 455 for M043 variety  
 Suffix 456 for M053 variety

# 1 6100 series

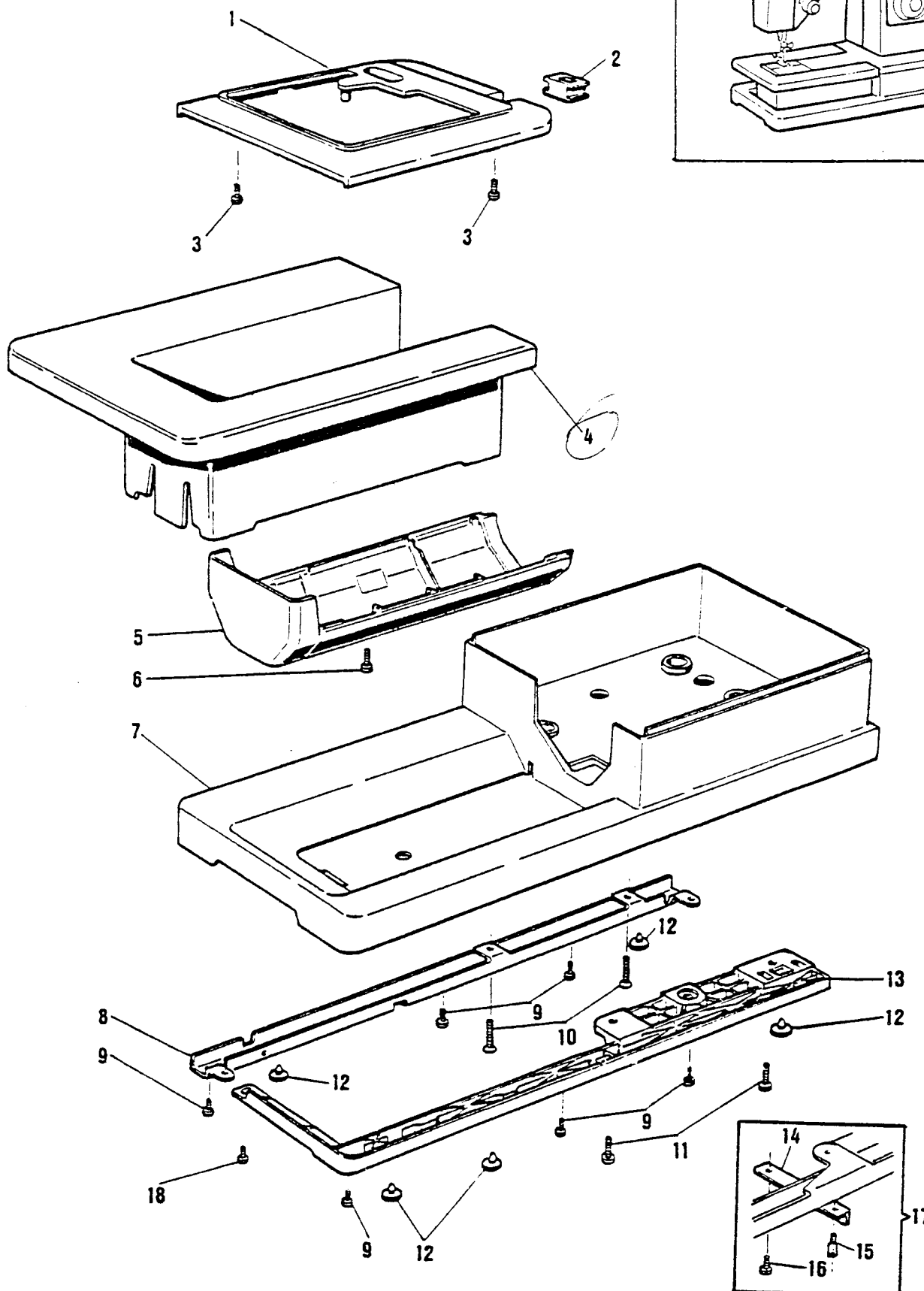
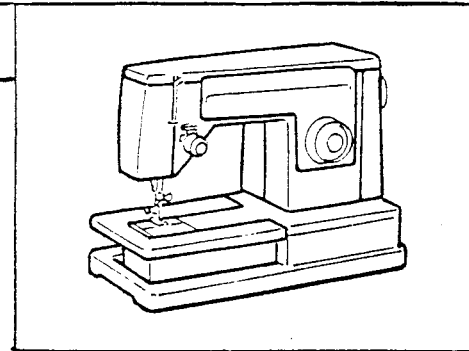

From the library of: Diamond Needle Corp

**1**

## LIST OF PARTS FOR MACHINES 6100 SERIES

REF. N.	PART. N.	6174	6184	6100	6106	6105	6104	6102	PART DESCRIPTION
1	422472-452	X							Bed cover
2	352584	X							Grommet
3	139986	X							Bed cover screw (4)
4	421657-451		X	X	X	X	X	X	Cloth plate
5	<del>352839-452</del>		X	X	X	X	X	X	<del>Bed cover (tubular)</del>
6	514690-451		X	X	X	X	X	X	Bed cover (tubular) screw
7	421655-451		X	X	X	X	X	X	Machine base
8	421660		X	X	X	X	X	X	Machine base support back
9	354738-451		X	X	X	X	X	X	Machine support (back and front) screw (8)
10	354790-451		X	X	X	X	X	X	Base support (back) screw (2)
11	354745-451		X	X	X	X	X	X	Base support (front) screw (2)
12	352797		X	X	X	X	X	X	Machine base cushion (5)
13	421736		X	X	X	X	X	X	Machine base support
14	352795		X	X	X	X	X	X	Bracket ( <u>for cabinets only</u> )
15	422481-451		X	X	X	X	X	X	Cushion ( <u>for cabinets only</u> )
16	354745-451		X	X	X	X	X	X	Bracket screw ( <u>for cabinets only</u> )
17	353035		X	X	X	X	X	X	Kit cpl. ( <u>for cabinets only</u> )
18	421712		X	X	X	X	X	X	Screw

2

# 6100 series

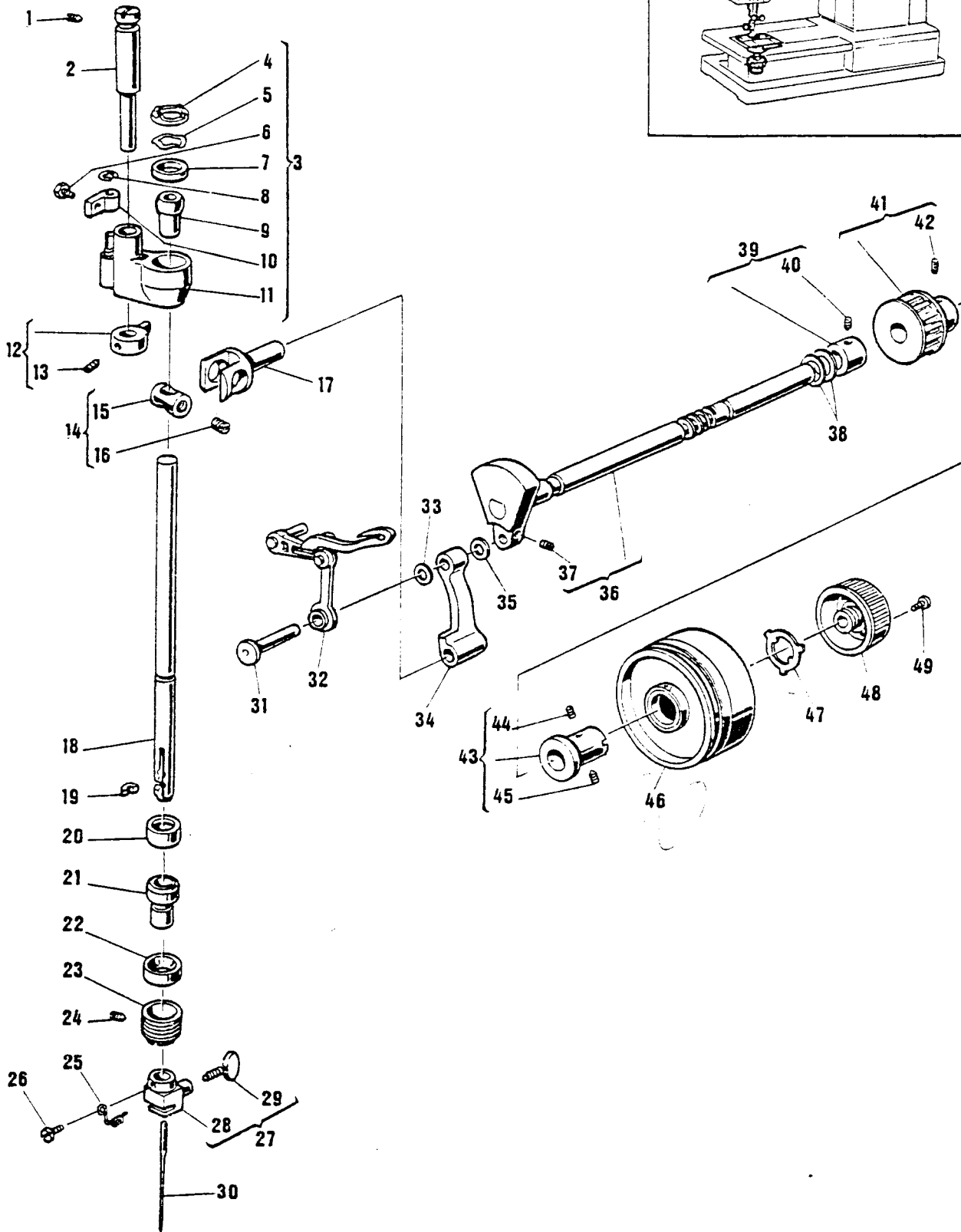
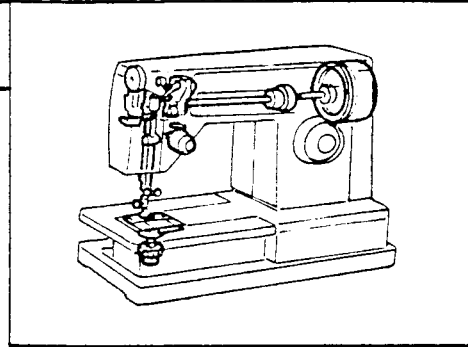

From the library of: Diamond Needle Corp

LIST OF PARTS FOR MACHINES 6100 SERIES

REF. N.	PART. N.	6174	6184	6100	6106	6105	6104	6102	PART DESCRIPTION
1	141918	X	X	X	X	X	X	X	Screw
2	445124	X	X	X	X	X	X	X	Hinge pin eccentric
3	422318	X	X	X	X	X	X	X	Needle bar vibrating bracket cpl.
4	422320	X	X	X	X	X	X	X	Retaining ring
5	502354	X	X	X	X	X	X	X	Washer
6	354621-451	X	X	X	X	X	X	X	Screw
7	507379	X	X	X	X	X	X	X	Ball bushing (upper) socket
8	507343	X	X	X	X	X	X	X	Retaining ring
9	37927	X	X	X	X	X	X	X	Ball bushing (upper)
10	37934	X	X	X	X	X	X	X	Bracket
11	422404	X	X	X	X	X	X	X	Vibrating bracket with hinge pin
12	44673	X	X	X	X	X	X	X	Hinge pin (eccentric) collar
13	141940	X	X	X	X	X	X	X	Set screw
14	37932	X	X	X	X	X	X	X	Needle bar connecting stud hinge pin cpl.
15	37931	X	X	X	X	X	X	X	Needle bar connecting stud hinge pin
16	141916	X	X	X	X	X	X	X	Set screw
17	37930	X	X	X	X	X	X	X	Needle bar connecting stud
18	352912	X	X	X	X	X	X	X	Needle bar
19	37943	X	X	X	X	X	X	X	Needle bar gib
20	44450	X	X	X	X	X	X	X	Ball bushing (lower) socket (upper)
21	37927	X	X	X	X	X	X	X	Ball bushing (lower)
22	507379	X	X	X	X	X	X	X	Ball bushing (lower) socket (lower)
23	44473	X	X	X	X	X	X	X	Ball bushing (lower) adjusting screw
24	141803	X	X	X	X	X	X	X	Set screw
25	319721	X	X	X	X	X	X	X	Needle clamp thread guide
26	141808	X	X	X	X	X	X	X	Screw
27	319729	X	X	X	X	X	X	X	Needle clamp cpl.
28	319728	X	X	X	X	X	X	X	Needle clamp body
29	511171	X	X	X	X	X	X	X	Needle thumb screw
30	Cat. 2045			X	X	X			Needle size 14 (fitted on machine)
	Cat. 2020	X	X				X	X	Needle size 14 (fitted on machine)
31	422310	X	X	X	X	X	X	X	Thread take-up stud
32	422307	X	X	X	X	X	X	X	Thread take-up
33	421356	X	X	X	X	X	X	X	Washer
34	352753	X	X	X	X	X	X	X	Needle bar connecting link
35	352754	X	X	X	X	X	X	X	Washer
36	352573	X	X	X	X	X	X	X	Arm shaft
37	354105	X	X	X	X	X	X	X	Thread take-up crank set screw
38	319764	X	X	X	X	X	X	X	Washer (2)
39	179861	X	X	X	X	X	X	X	Arm shaft retaining collar cpl.
40	141916	X	X	X	X	X	X	X	Set screw
41	353239		X	X	X	X	X	X	Arm shaft belt drive pulley cpl.
42	141918		X	X	X	X	X	X	Arm shaft belt drive pulley set screw
43	44679	X	X	X	X	X	X	X	Clamp stop motion flanged bushing cpl.
44	141916	X	X	X	X	X	X	X	Set screw
45	141915	X	X	X	X	X	X	X	Flanged bushing positioning screw
46	353107-452	X	X	X	X	X	X	X	Hand wheel
47	44464	X	X	X	X	X	X	X	Clamp stop motion clamp washer
48	352589-452	X	X	X	X	X	X	X	Clamp stop motion clamp screw
49	141914	X	X	X	X	X	X	X	Clamp stop motion clamp stop screw

From the library of: Diamond Needle Corp



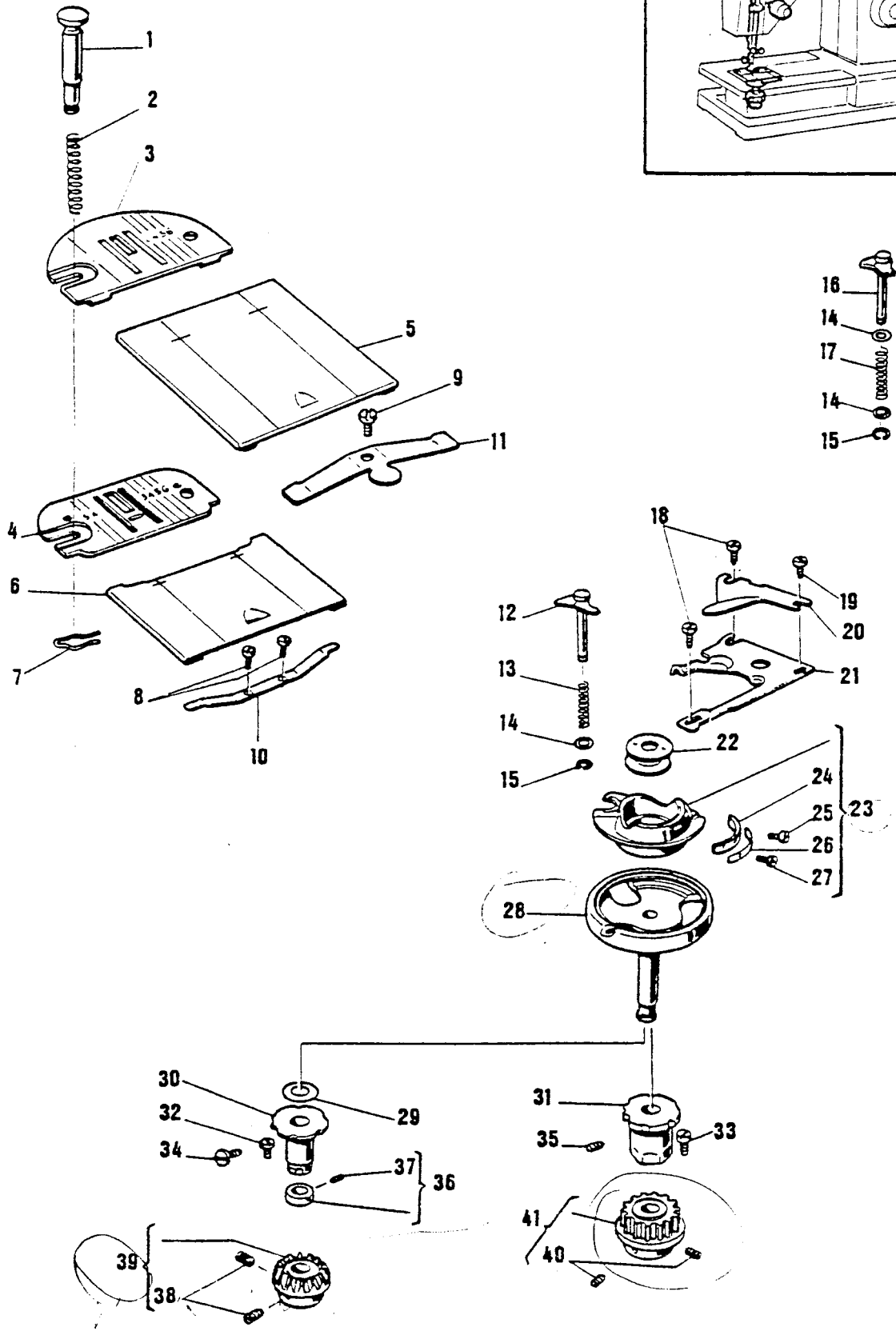
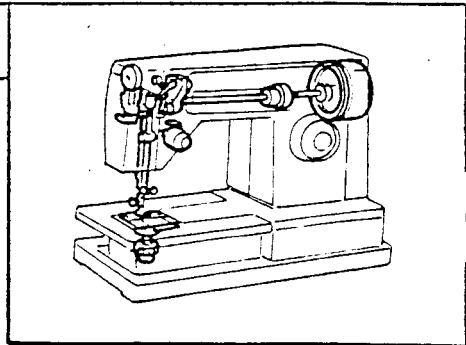

From the library of: Diamond Needle Corp

## LIST OF PARTS FOR MACHINES 6100 SERIES

REF. N.	PART. N.	6174	6184	6100	6106	6105	6104	6102	PART DESCRIPTION
1	102840	X	X	X	X	X	X	X	Needle plate clamp
2	153930	X	X	X	X	X	X	X	Needle plate clamp spring
3	352461	X							Needle plate
4	312391		X	X	X	X	X	X	Needle plate
5	44838	X							Bed slide
6	422229		X	X	X	X	X	X	Bed slide
7	179658	X	X	X	X	X	X	X	Clip
8	354134		X	X	X	X	X	X	Bed slide spring screw (2)
9	354799	X							Bed slide spring screw
10	103344		X	X	X	X	X	X	Bed slide spring
11	37239	X							Bed slide spring
12	422129		X	X	X	X	X	X	Retaining plate
13	319735		X	X	X	X	X	X	Spring
14	319737-451	X	X	X	X	X	X	X	Washer
15	319736	X	X	X	X	X	X	X	Clip
16	353123	X							Retaining plate
17	353122	X							Spring
18	354229-451	X	X	X	X	X	X	X	Position plate screw (2)
19	354227-451	X	X	X	X	X	X	X	Position plate screw
20	381903	X	X	X	X	X	X	X	Retaining plate (Adjustable)
21	44873	X	X	X	X	X	X	X	Position plate
22	172336	X	X	X	X	X	X	X	Bobbin (Plastic)
23	421325	X	X	X	X	X	X	X	Bobbin case cpl. (EUROPE)
	421326	X	X	X	X	X	X	X	Bobbin case cpl. (USA and CANADA)
24	310884-451	X	X	X	X	X	X	X	Tension spring segment (USA and CANADA)
	310884-452	X	X	X	X	X	X	X	Tension spring segment (EUROPE)
25	139975	X	X	X	X	X	X	X	Tension spring segment screw
26	310883	X	X	X	X	X	X	X	Tension spring
27	354183-451	X	X	X	X	X	X	X	Tension regulating screw
28	353104	X	X	X	X	X	X	X	Rotating hook
29	506164		X	X	X	X	X	X	Washer (1)
30	353237		X	X	X	X	X	X	Flanged bushing (eccentric)
31	446942	X							Flanged bushing (eccentric)
32	354133-451		X	X	X	X	X	X	Position screw
33	139943	X							Position screw
34	514689-451		X	X	X	X	X	X	Bushing set screw
35	141925	X							Bushing set screw
36	116084		X	X	X	X	X	X	Rotating hook collar
37	114312		X	X	X	X	X	X	Collar set screw
38	514721		X	X	X	X	X	X	Bevel gear set screw (2)
39	103361-002		X	X	X	X	X	X	Bevel gear cpl.
40	354774-451	X							Belt drive pulley set screw (2)
41	352882	X							Belt drive pulley cpl.

2

# 6100 series

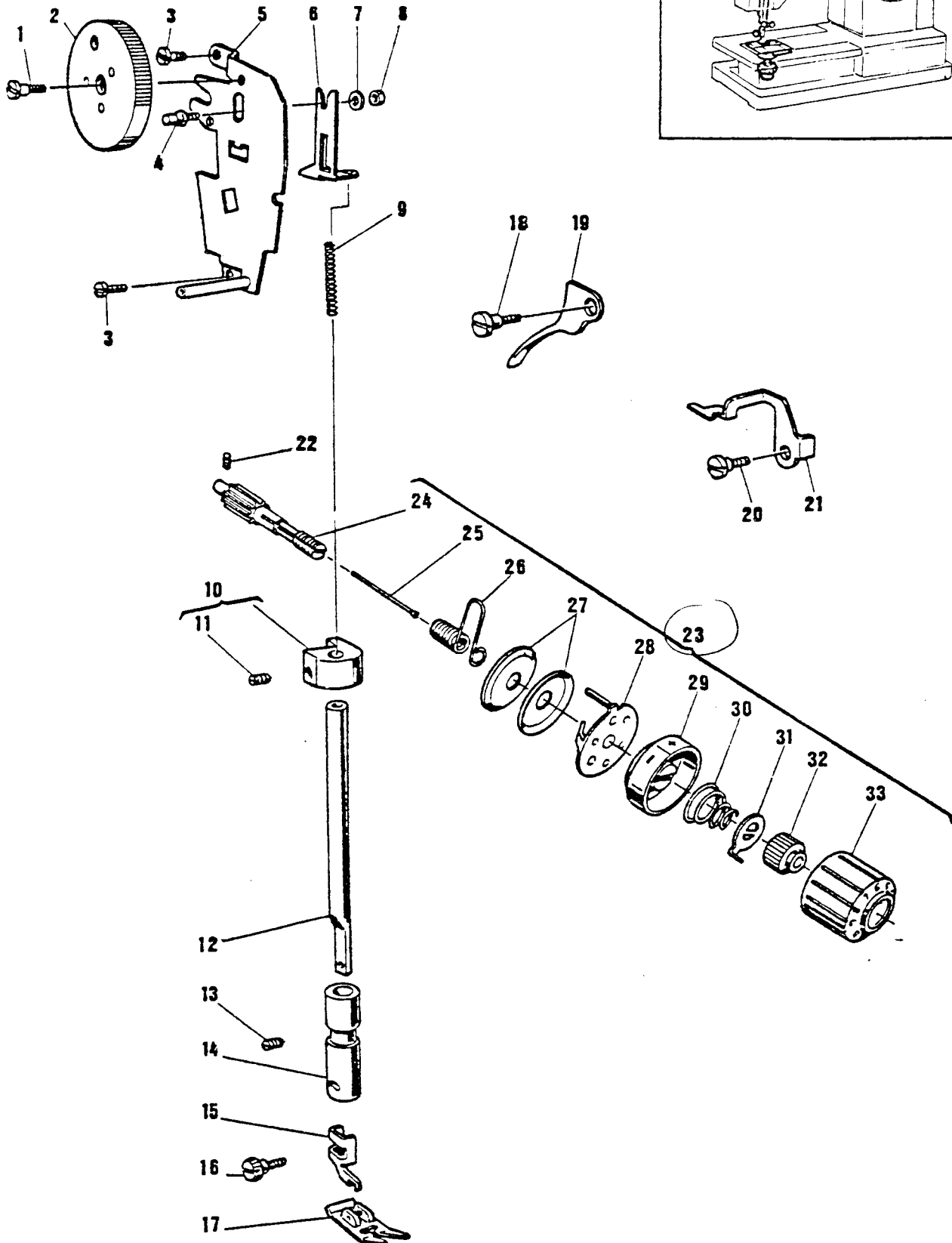
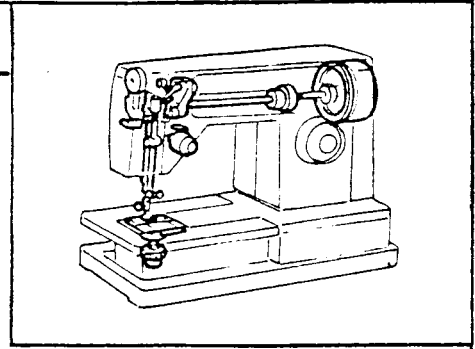

From the library of: Diamond Needle Corp

## LIST OF PARTS FOR MACHINES 6100 SERIES

REF. N.	PART. N.	6174	6184	6100	6106	6105	6104	6102	PART DESCRIPTION
1	141941	X	X	X	X	X	X	X	Pressure knob screw
2	421717-451	X	X	X	X	X	X	X	Pressure regulating knob
3	141913	X	X	X	X	X	X	X	Bracket screw (2)
4	422317	X	X	X	X	X	X	X	Pressure regulating knob pin
5	422313	X	X	X	X	X	X	X	Pressure regulating knob bracket
6	422316	X	X	X	X	X	X	X	Pressure regulating knob bracket slide
7	422241	X	X	X	X	X	X	X	Washer
8	514674	X	X	X	X	X	X	X	Nut
9	44449	X	X	X	X	X	X	X	Presser bar spring
10	44444	X	X	X	X	X	X	X	Presser bar guide bracket cpl.
11	354420-451	X	X	X	X	X	X	X	Set screw
12	446740	X	X	X	X	X	X	X	Presser bar
13	141803	X	X	X	X	X	X	X	Bushing set screw
14	37958	X	X	X	X	X	X	X	Presser bar bushing
15	155964	X	X	X	X	X	X	X	Presser bar shank
16	354135-451	X	X	X	X	X	X	X	Presser foot thumb screw
17	155962	X	X	X	X	X	X	X	Presser foot (zig-zag)
18	141846	X	X	X	X	X	X	X	Hinge screw
19	44445	X	X	X	X	X	X	X	Presser bar lifter
20	141786 ✓	X	X	X	X	X	X	X	Hinge screw
21	44829	X	X	X	X	X	X	X	Tension releasing lever
22	141803	X	X	X	X	X	X	X	Set screw
23	422403-457	X	X	X	X	X	X	X	Tension cpl.
24	353T24	X	X	X	X	X	X	X	Tension stud
25	37986	X	X	X	X	X	X	X	Tension releasing pin
26	66774-002	X	X	X	X	X	X	X	Thread take-up spring
27	2102	X	X	X	X	X	X	X	Tension disc (2)
28	45343	X	X	X	X	X	X	X	Spring thread guard
29	421739-451	X	X	X	X	X	X	X	Tension spring cup
30	125314	X	X	X	X	X	X	X	Tension spring
31	37984	X	X	X	X	X	X	X	Tension indicator stop washer
32	507405	X	X	X	X	X	X	X	Tension indicator adaptor
33	422402-451	X	X	X	X	X	X	X	Tension indicator

3

# 6100 series

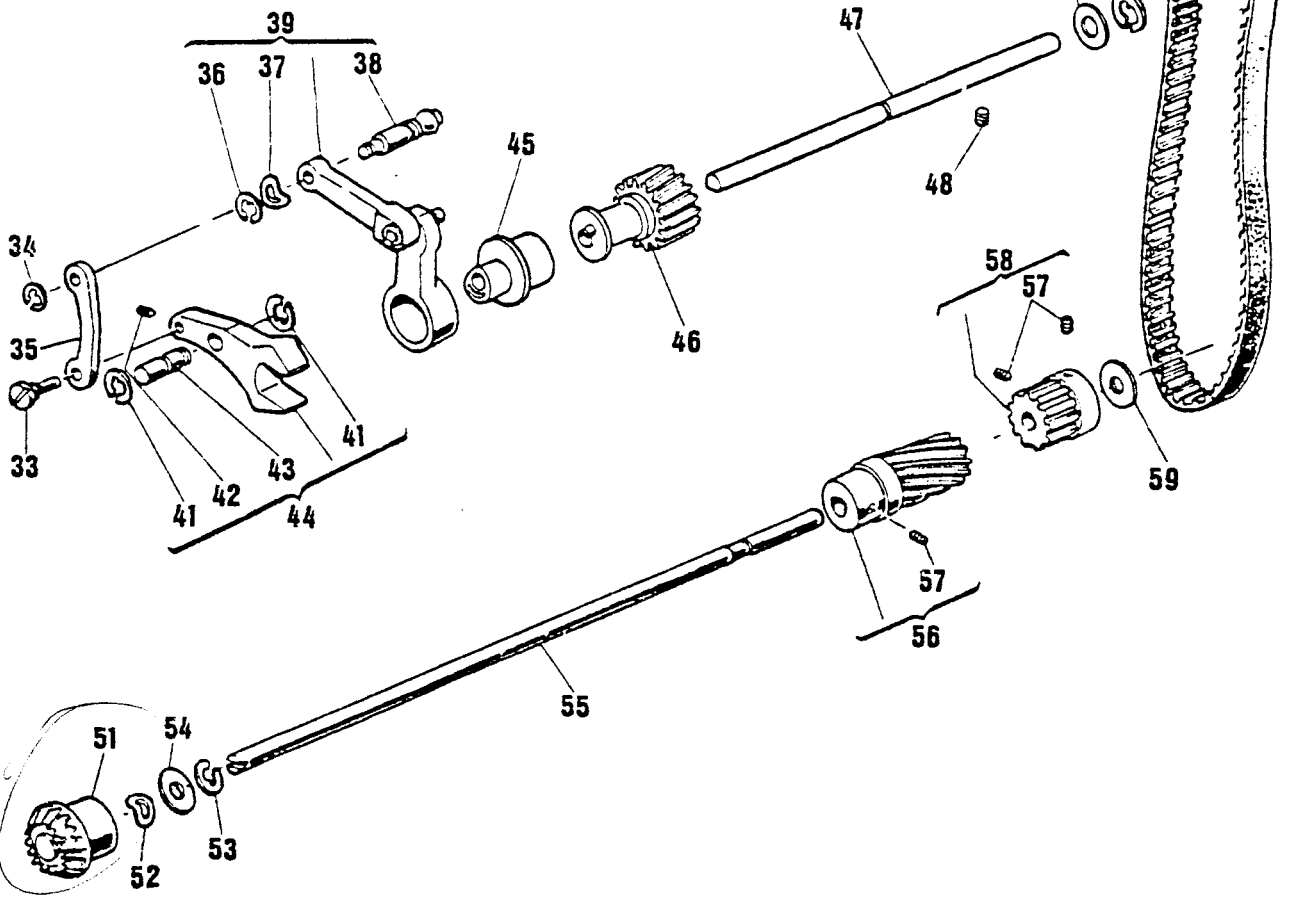
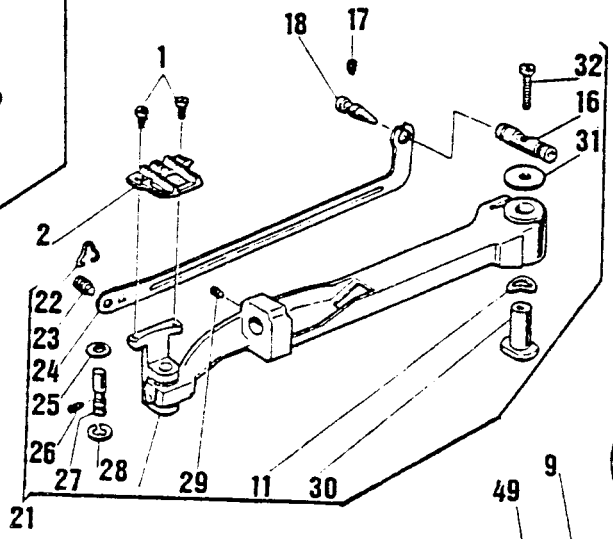
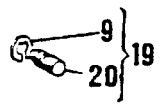
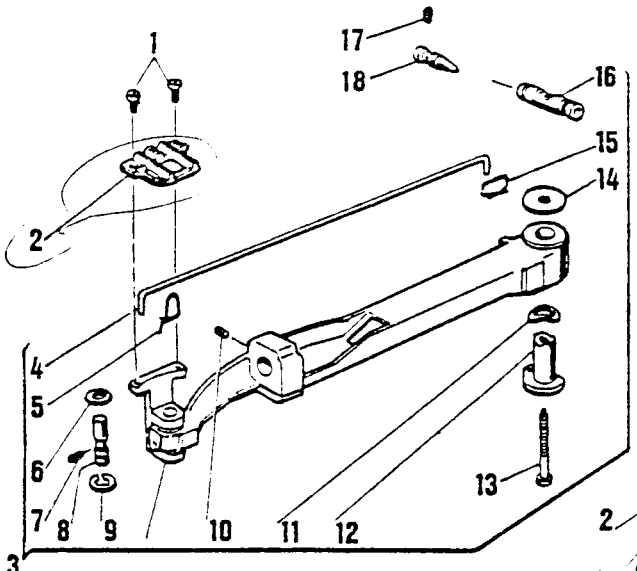
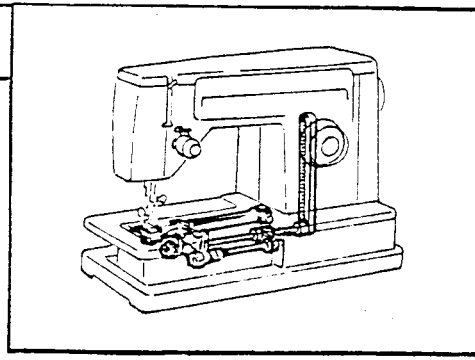

From the library of: Diamond Needle Corp

LIST OF PARTS FOR MACHINES 6100 SERIES

REF. N.	PART. N.	6174	6184	6100	6106	6105	6104	6102	PART DESCRIPTION
1	141920		X	X	X	X	X	X	Feed dog screw (2)
2	422406		X	X	X	X	X	X	Feed dog
3	422385		X	X	X	X	X	X	Feed bar cpl.
4	422335-000		X	X	X	X	X	X	Compensating link
5	422561-000		X	X	X	X	X	X	Retaining spring
6	511210		X	X	X	X	X	X	Washer
7	544100		X	X	X	X	X	X	Screw
8	511052		X	X	X	X	X	X	Stud
9	511213		X	X	X	X	X	X	Retaining ring
10	549308		X	X	X	X	X	X	Set screw
11	511211		X	X	X	X	X	X	Washer
12	422340		X	X	X	X	X	X	Bushing
13	514744-451		X	X	X	X	X	X	Feed bar guide pin screw
14	422338		X	X	X	X	X	X	Washer
15	422337-000		X	X	X	X	X	X	Retaining spring
16	421814		X	X	X	X	X	X	Feed bar guide pin
17	514556-451		X	X	X	X	X	X	Set screw
18	507917		X	X	X	X	X	X	Feed bar guide pin centre (black)
19	502310		X	X	X	X	X	X	Feed bar guide pin centre cpl. (front)
20	502309		X	X	X	X	X	X	Feed bar guide pin centre (front)
21	353195		X	X	X	X	X	X	Feed bar cpl. (Alternate To 422385)
22	511075		X	X	X	X	X	X	Retaining spring
23	141827		X	X	X	X	X	X	Screw stud
24	174216		X	X	X	X	X	X	Compensating link
25	174251		X	X	X	X	X	X	Washer
26	139878		X	X	X	X	X	X	Screw
27	174217		X	X	X	X	X	X	Stud
28	163562		X	X	X	X	X	X	Retaining ring
29	141812		X	X	X	X	X	X	Set screw
30	507822		X	X	X	X	X	X	Bushing
31	507824		X	X	X	X	X	X	Washer
32	514692		X	X	X	X	X	X	Feed bar guide pin screw
33	511056		X	X	X	X	X	X	Hinge stud (eccentric)
34	507063		X	X	X	X	X	X	Retaining ring
35	511016		X	X	X	X	X	X	Feed lifting fork connection
36	502744		X	X	X	X	X	X	Retaining ring
37	422388		X	X	X	X	X	X	Washer
38	422345		X	X	X	X	X	X	Hinge stud (eccentric)
39	422347		X	X	X	X	X	X	Drive connection
40	421875		X	X	X	X	X	X	Belt tension adjuster lever
41	511213		X	X	X	X	X	X	Retaining ring
42	514547		X	X	X	X	X	X	Set screw
43	511057		X	X	X	X	X	X	Hinge stud
44	422514		X	X	X	X	X	X	Feed lifting fork cpl.
45	422361		X	X	X	X	X	X	Feed eccentric
46	422325 ✓		X	X	X	X	X	X	Feed drive shaft gear cpl.
47	422324		X	X	X	X	X	X	Feed drive shaft
48	514556		X	X	X	X	X	X	Set screw
49	116073		X	X	X	X	X	X	Drive shaft washer
50	421035-001		X	X	X	X	X	X	Drive shaft belt
51	422395		X	X	X	X	X	X	Drive shaft bevel gear
52	507722		X	X	X	X	X	X	Rotating hook drive shaft spring washer
53	511213		X	X	X	X	X	X	Retaining ring
54	116073		X	X	X	X	X	X	Drive shaft washer
55	422394		X	X	X	X	X	X	Rotating hook drive shaft
56	422408		X	X	X	X	X	X	Drive shaft gear cpl. ←
57	514556		X	X	X	X	X	X	Set screw
58	352871		X	X	X	X	X	X	Drive shaft gear
59	421356		X	X	X	X	X	X	Damping washer

From the library of: Diamond Needle Corp

3

# 6100 series

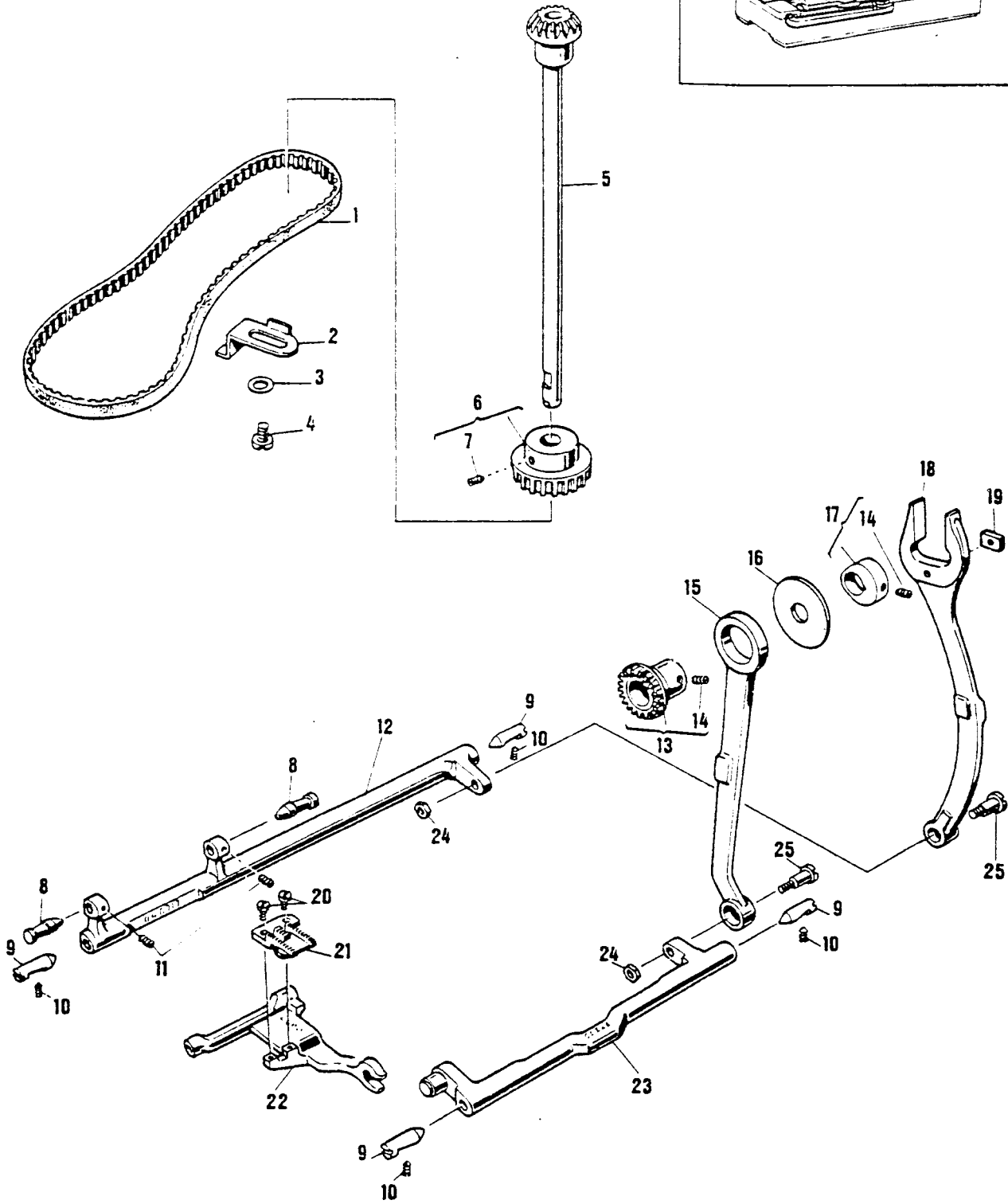
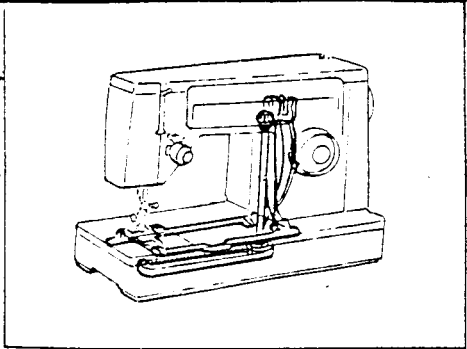

From the library of: Diamond Needle Corp

## LIST OF PARTS FOR MACHINES 6100 SERIES

REF. N.	PART. N.	6174	6184	6100	6106	6105	6104	6102	PART DESCRIPTION
1	37977	X							Rotating hook drive belt
2	446736	X							Driving belt tension adjuster
3	446737	X							Friction washer
4	139909	X							Adjuster screw
5	37231	X							Arm shaft (upright)
6	446822	X							Belt drive pulley cpl.
7	141803	X							Set screw
8	446716	X							Feed bar centre (2)
9	179880	X							Feed lifting rock shaft centre
10	141925	X							Set screw (4)
11	141938	X							Set screw (2)
12	446717	X							Feed rock shaft
13	37229	X							Bevel gear and feed lifting cpl.
14	141918	X							Set screw
15	37288	X							Connecting rod
16	37284-001	X							Retaining washer
17	37281	X							Feed cam cpl.
18	37283	X							Feed forked connection
19	319820	X							Slide block
20	141920	X							Feed dog screw (2)
21	422407	X							Feed dog
22	37280	X							Feed bar
23	37286	X							Feed lifting rock shaft
24	53648	X							Nut
25	141805	X							Hinge screw (eccentric)



4

# 6100 series

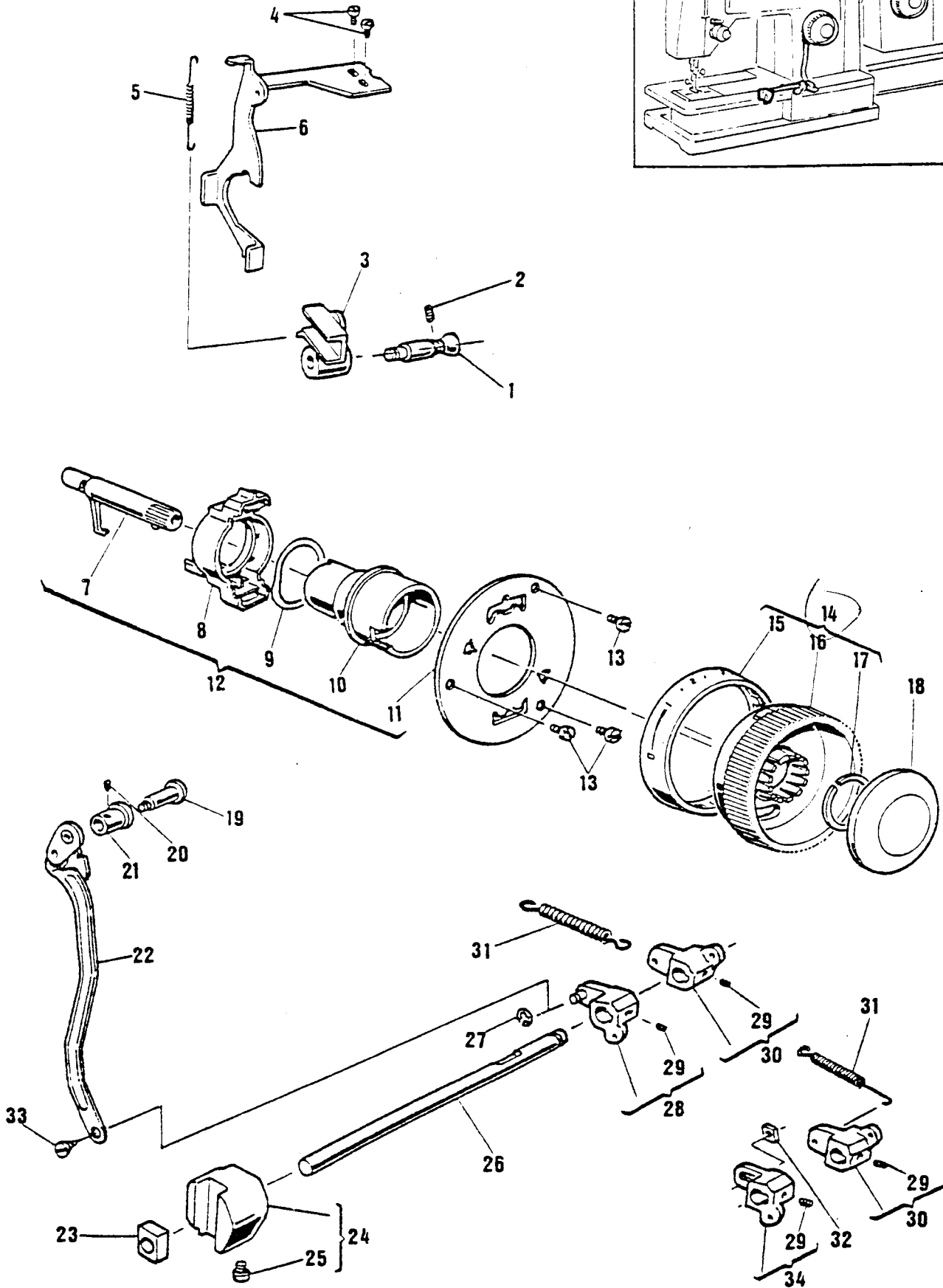
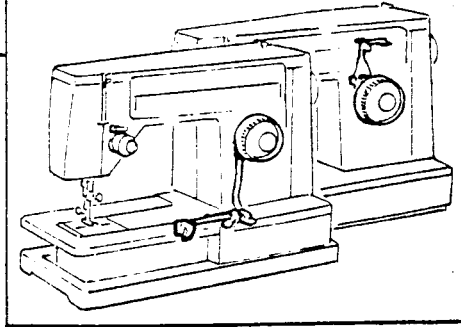

From the library of: Diamond Needle Corp

LIST OF PARTS FOR MACHINES 6100 SERIES

REF. N.	PART. N.	6174	6184	6100	6106	6105	6104	6102	PART DESCRIPTION
1	353182	X							Hinge screw
2	141803	X							Screw
3	353181	X							Feed regulator
4	354799	X							Bracket screw
5	37913	X							Feed regulator return spring
6	353179	X							Feed regulator control arm
7	422240							X	Positioning pin
8	422237							X	Feed regulator cam
9	422238							X	Friction spring
10	422236							X	Feed regulator cam
11	446932							X	Mounting plate
12	422253							X	Feed regulator cpl.
13	354799							X	Mounting plate screw
14	422001-451							X	Control dial cpl.
15	421750-451							X	Control dial ring
16	421737-451							X	Control dial
17	422083							X	Retaining ring
18	421738-451							X	Reverse feed push button
19	354733-451							X	Hinge screw
20	141803		X					X	Set screw
21	352801		X					X	Hinge screw bushing
22	422217		X					X	Feed regulator control arm
23	511030		X					X	Slide block
24	511484		X					X	Feed regulator cpl.
25	353126		X					X	Feed regulator set screw
26	422214		X					X	Feed regulator shaft
27	507063		X					X	Retaining ring
28	422210							X	Feed regulator
29	514509		X					X	Set screw
30	422209		X					X	Feed regulator
31	421959							X	Tension spring
31 a	353188		X						Tension spring
32	514698-451		X						Nut
33	353190		X						Screw
34	422212		X						Feed regulator

From the library of: Diamond Needle Corp

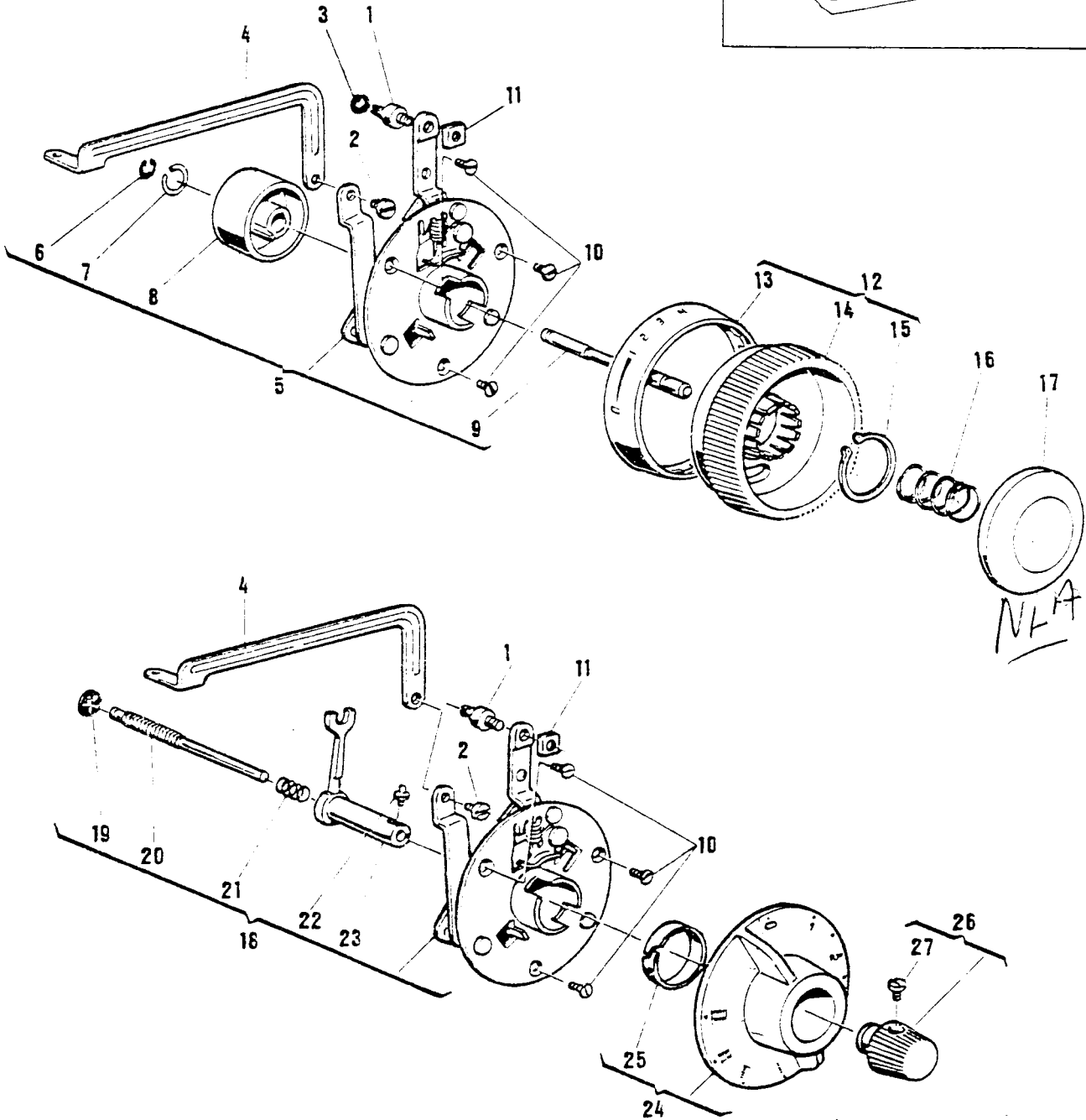
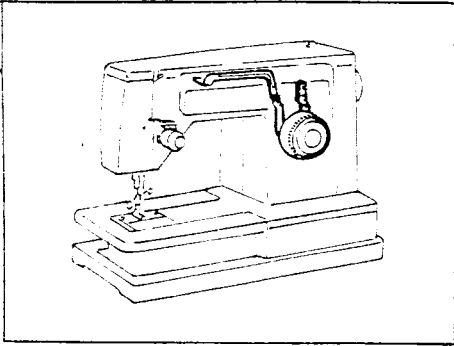

4

LIST OF PARTS FOR MACHINES 6100 SERIES

REF. N.	PART. N.	6174	6184	6100	6106	6105	6104	6102	PART DESCRIPTION
1	514745	X	X	X	X	X	X		Bearing screw
2	139866	X	X	X	X	X	X		Hinge screw
3	507063			X	X	X	X		Retaining ring
4	421926	X	X	X	X	X	X		Bight control lever link
5	422363			X	X	X	X		Buttonholer and feed regulator cpl.
6	507063			X	X	X	X		Retaining ring
7	421925			X	X	X	X		Retaining ring
8	421852			X	X	X	X		Feed regulator cam
9	421935			X	X	X	X		Reverse feed pin
10	139868	X	X	X	X	X	X		Screw
11	514698-451	X	X	X	X	X	X		Nut
12	<del>422020-451</del>			X	X	X			Control dial cpl. (Chromium plated)
	<del>422019-451</del>						X		Control dial cpl. (Chromium plated)
	<del>422021-451</del>				X	X	X		Control dial cpl. (Plastic colour)
	<del>422021-451</del>			X					Control dial cpl. (Plastic colour only for 6120)
13	<del>421938-451</del>			X	X	X	X		Control dial ring (with red mark)
	<del>421938-452</del>						X		Control dial ring (with yellow mark)
14	421864-451			X	X	X	X		Control dial (Chromium plated)
	421862-451				X	X	X		Control dial (Plastic colour)
	421862-451			X					Control dial (Plastic colour only for 6120)
15	421871			X	X	X	X		Retaining ring
16	421934			X	X	X	X		Pressure spring
17	421933-451			X	X	X	X		Reverse feed push-button NLA
18	422089	X							Buttonholer and feed regulator cpl.
18 a	353187		X						Buttonholer and feed regulator cpl.
19	446897	X							Retaining ring
20	352820	X							Feed regulator positioning pin
20 a	353185		X						Feed regulator positioning pin
21	446896	X	X						Friction spring
22	352583	X	X						Reverse feed cam follower
23	446918	X	X						Feed regulator positioning pin carrier.
24	353078-452	X	X						Control dial cpl.
25	445512	X	X						Retaining ring
26	445307-462	X	X						Feed regulator positioning pin knob
27	354592	X	X						Screw

From the library of: Diamond Needle Corp

4

# 6100 series

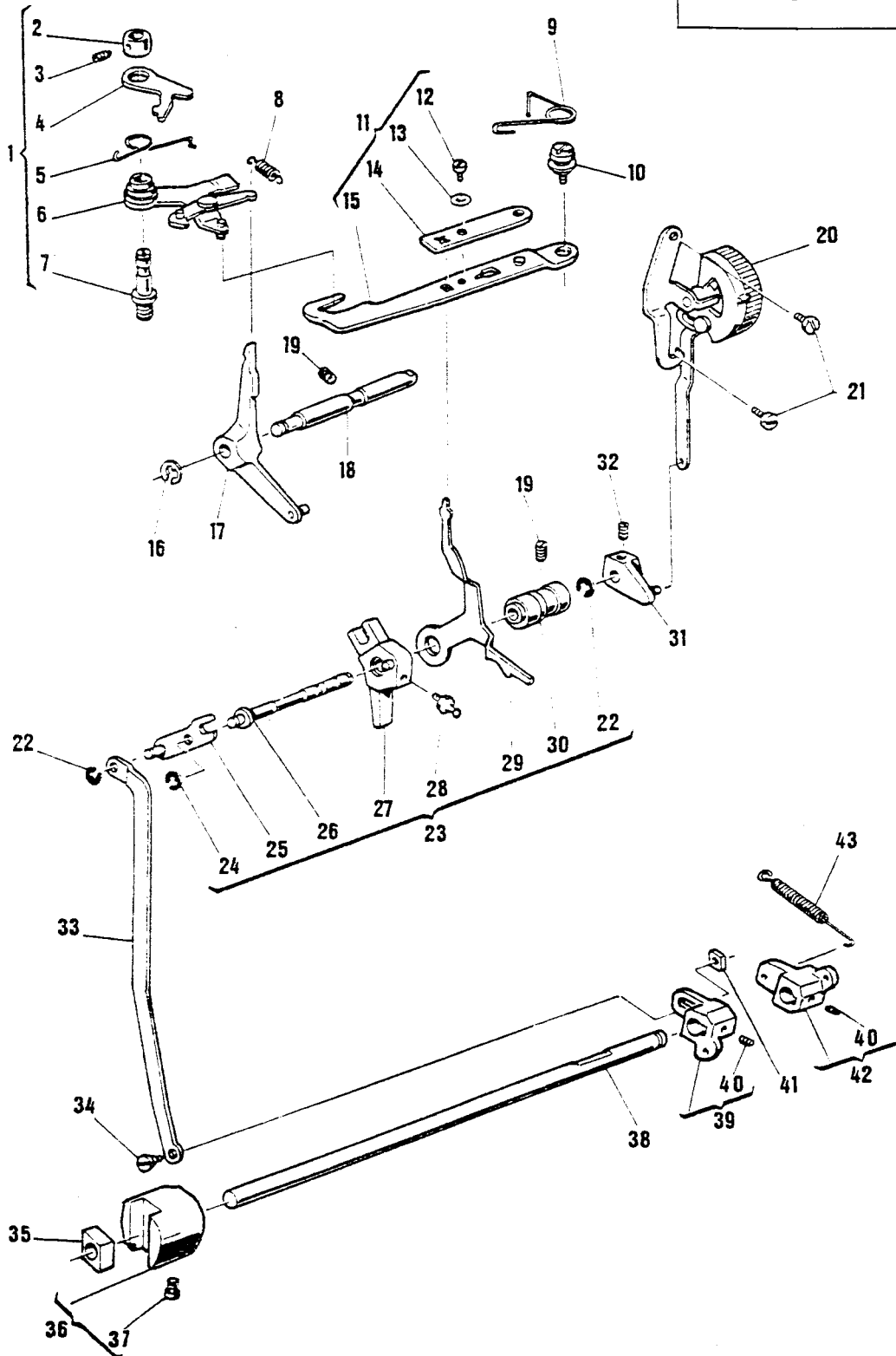
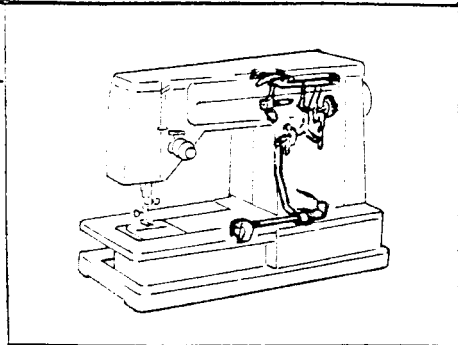

From the library of: Diamond Needle Corp

## LIST OF PARTS FOR MACHINES 6100 SERIES

REF. N.	PART. N.	6174	6184	6100	6106	6105	6104	6102	PART DESCRIPTION
1	421997			X	X	X	X		Cam feed disc drive lever
2	353033			X	X	X	X		Feed shaft drive collar
3	354795-451			X	X	X	X		Set screw
4	421130			X	X	X	X		Cam feed disc follower
5	421138			X	X	X	X		Torsion spring
6	421133			X	X	X	X		Cam feed disc drive lever cpl.
7	421131			X	X	X	X		Bearing stud
8	421945			X	X	X	X		Tension spring
9	421950			X	X	X	X		Torsion spring
10	421949-451			X	X	X	X		Hinge screw
11	421946			X	X	X	X		Clutch lever cpl.
12	514554-451			X	X	X	X		Screw
13	506125			X	X	X	X		Washer
14	421948			X	X	X	X		Adjusting lever
15	421947			X	X	X	X		Clutch lever
16	511213			X	X	X	X		Retaining ring
17	421941			X	X	X	X		Transmission lever cpl.
18	421129			X	X	X	X		Transmission lever shaft (eccentric)
19	141803			X	X	X	X		Set screw
20	421951-452			X	X	X	X		Feed balancing bracket cpl. ( <u>chromium plated</u> )
	421951-451				X	X	X		Feed balancing bracket cpl. ( <u>plastic colour</u> )
	421951-451			X					Feed balancing bracket cpl. ( <u>plastic colour only for 6120</u> )
21	354084			X	X	X	X		Screw
22	507309			X	X	X	X		Retaining ring
23	421989			X	X	X	X		Bearing stud cpl.
24	507343			X	X	X	X		Retaining ring
25	421991			X	X	X	X		Adjusting lever cpl.
26	421863			X	X	X	X		Bearing stud
27	421856			X	X	X	X		Feed regulator control arm
28	421857			X	X	X	X		Feed regulator control arm (ball)
29	421929			X	X	X	X		Actuating lever
30	421978			X	X	X	X		Eccentric bushing
31	421956			X	X	X	X		Driving arm eccentric
32	354085-451			X	X	X	X		Set screw
33	421931			X	X	X	X		Connection link
34	422244			X	X	X	X		Screw
35	511030			X	X	X	X		Slide block
36	511484			X	X	X	X		Feed regulator cpl.
37	351126			X	X	X	X		Feed regulator set screw
38	422214			X	X	X	X		Feed regulator shaft
39	422212			X	X	X	X		Feed regulator
40	514509			X	X	X	X		Set screw
41	514698-451			X	X	X	X		Nut
42	422209			X	X	X	X		Feed regulator
43	421959			X	X	X	X		Tension spring

# 6100 series

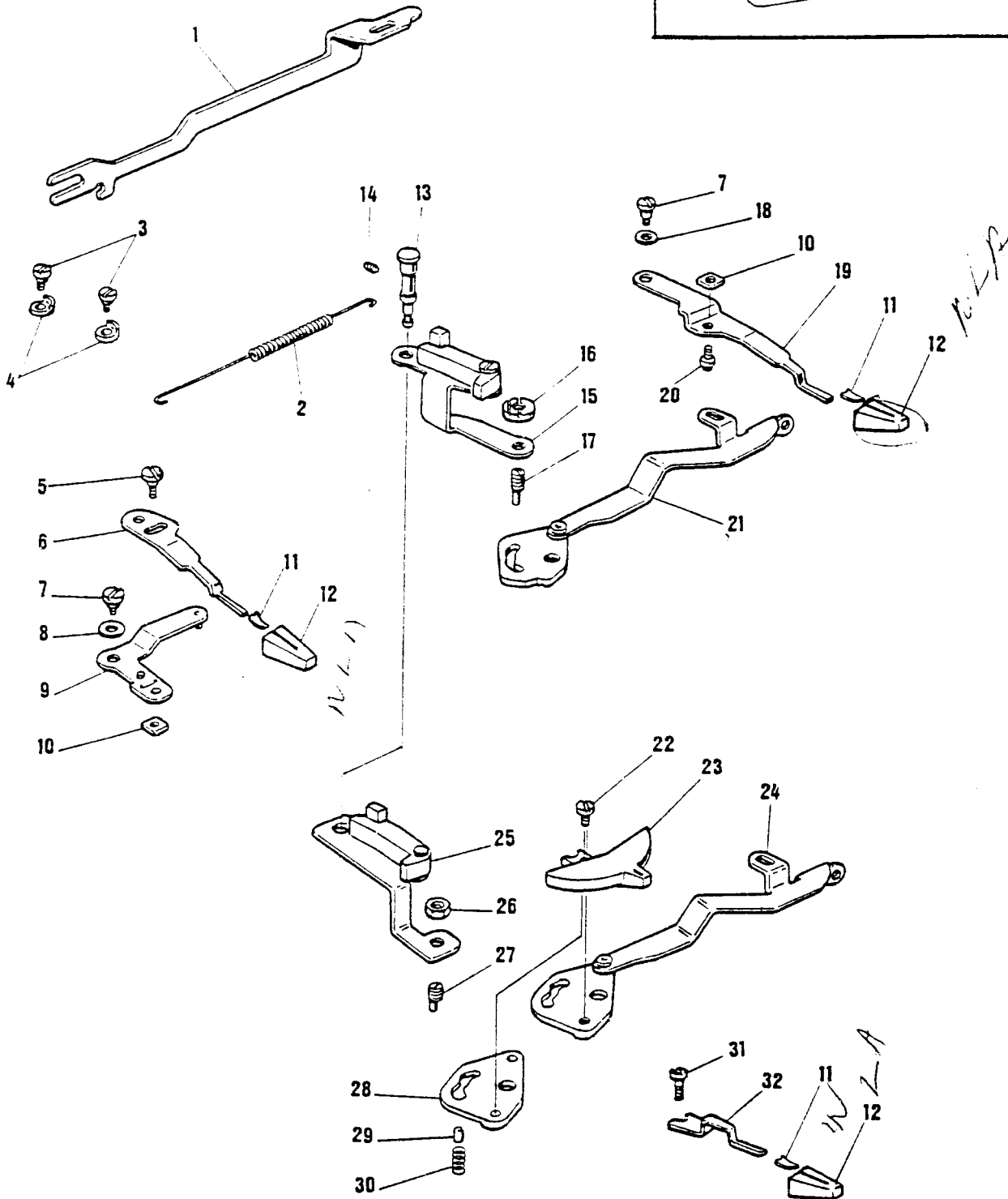
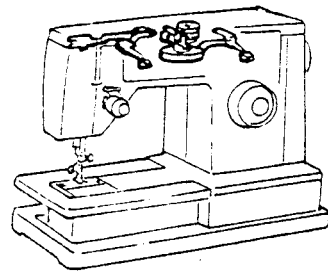

## LIST OF PARTS FOR MACHINES 6100 SERIES

REF. N.	PART. N.	6174	6184	6100	6106	6105	6104	6102	PART DESCRIPTION
1	37933	X	X	X	X	X	X	X	Needle bar driving arm
2	37942	X	X	X	X	X	X	X	Tension spring
3	141787	X	X	X	X	X	X	X	Stop screw (2)
4	37248	X	X	X	X	X	X	X	Control lever link stop (2)
5	514730-451	X	X	X	X	X	X	X	Screw
	141913							X	Screw
6	421858	X	X	X	X	X	X	X	Bight amplitude control lever
7	141786	X	X	X	X	X	X	X	Hinge screw
8	49204	X	X	X	X	X	X	X	Friction washer
	446736							X	Friction washer
9	421984	X	X	X	X	X	X	X	Control lever link
	37246							X	Control lever link
10	514707-451	X	X	X	X	X	X	X	Nut
11	37244	X	X	X	X	X	X	X	Control lever knob spring clip
12	421883-451			X	X	X	X	X	Control lever knob (Chromium plated)
	421883-452	X	X	X	X	X	X	X	Control lever knob (Plastic colour)
13	37941	X	X	X	X	X	X	X	Hinge stud
14	354196-451	X	X	X	X	X	X	X	Set screw
15	421886			X	X	X			Slide bracket
16	179739-451			X	X	X			Eccentric screw stud nut
17	445347			X	X	X			Eccentric screw stud
18	49204			X	X	X			Friction washer
19	421859			X	X	X			Needle position lever
20	421893			X	X	X			Stud
21	421889			X	X	X			Needle position selector lever cpl.
22	139943						X	X	Screw
23	421895-451						X	X	Needle position selector dial (Chromium plated)
	421895-452						X	X	Needle position selector dial (Plastic colour)
24	422075						X	X	Needle position selector lever cpl.
25	319798						X	X	Slide bracket
26	53641						X	X	Eccentric screw stud nut
27	44471						X	X	Eccentric screw stud
28	37953						X	X	Bracket
29	37955	X	X	X	X	X	X	X	Positioning pin
30	37956	X	X	X	X	X	X	X	Positioning pin spring
31	141913	X	X						Screw
32	422428	X	X						Needle position lever



# 5

# 6100 series

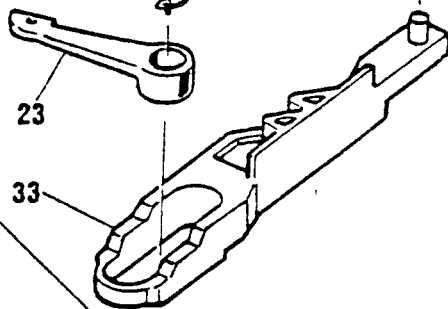
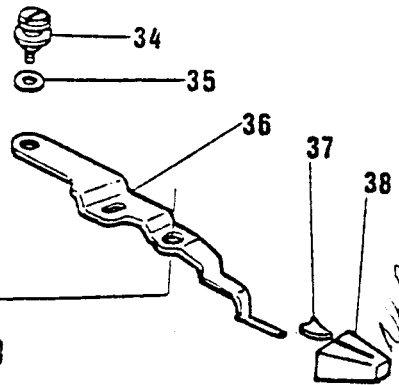
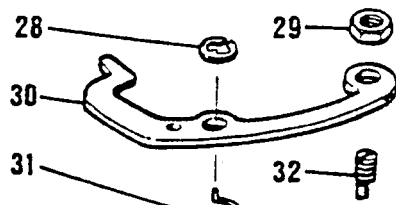
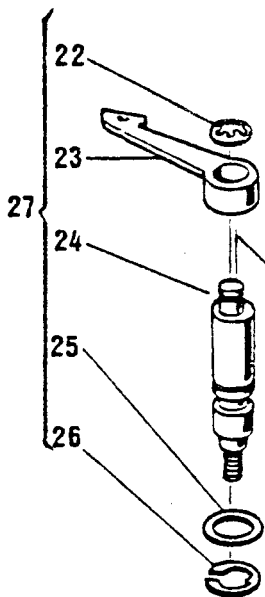
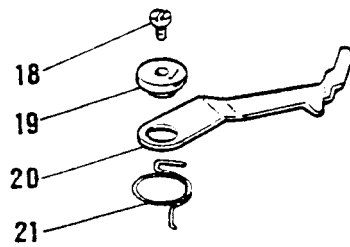
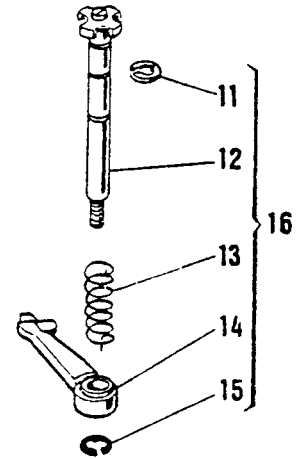
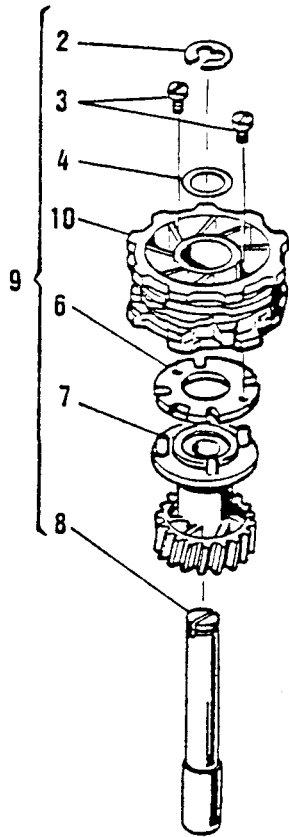
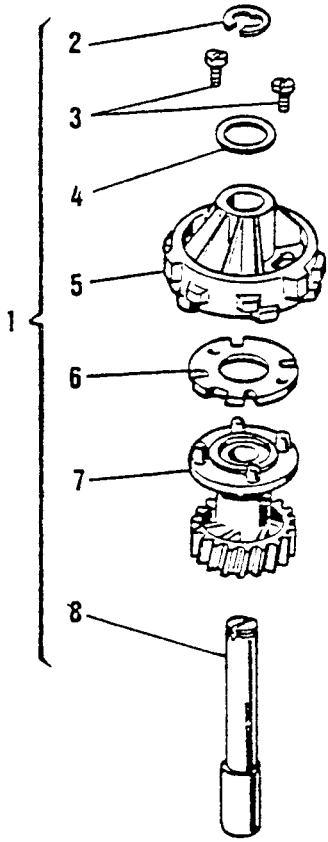
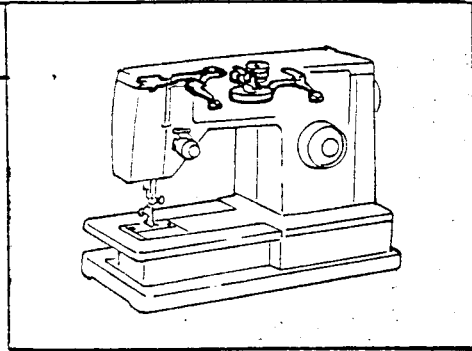

## LIST OF PARTS FOR MACHINES 6100 SERIES

REF. N.	PART. N.	6174	6184	6100	6106	6105	6104	6102	PART DESCRIPTION
1	353175	X	X						Disc driving gear cpl.
1 a	422080						X	X	Disc driving gear cpl
2	422441	X	X	X	X	X	X	X	Retaining ring
3	422440	X	X	X	X	X	X	X	Disc positioning screw (2)
4	422074	X	X	X	X	X	X	X	Washer
5	422288						X	X	Disc stack
5 a	353174	X	X						Disc stack
6	422260	X	X	X	X	X	X	X	Disc mounting plate
7	422202	X	X	X	X	X	X	X	Disc driving gear
8	422073	X	X	X	X	X	X	X	Disc driving gear shaft
9	422079			X	X	X			Disc driving gear cpl.
10	422206			X	X	X			Disc stack
11	421912			X	X	X			Crescent ring
12	421898			X	X	X			Hinge stud
13	421897			X	X	X			Disc follower spring
14	421896			X	X	X			Disc follower
15	511213			X	X	X			Retaining ring
16	421730-451				X				Disc follower cpl.
	421731-451					X			Disc follower cpl.
	421732-452			X					Disc follower cpl.
17	421969-451				X				Disc selector dial ( <u>Plastic colour</u> )
	421969-452				X				Disc selector dial ( <u>Chromium plated</u> )
	422066-451					X			Disc selector dial ( <u>Plastic colour</u> )
	422066-452					X			Disc selector dial ( <u>Chromium plated</u> )
	422065-451			X					Disc selector dial ( <u>Chromium plated</u> )
	422065-452			X					Disc selector dial ( <u>Plastic colour</u> )
18	514733-451			X	X	X			Bushing screw
19	422230			X	X	X			Disengaging lever bushing
20	421901			X	X	X			Disengaging lever
21	421902			X	X	X			Disengaging lever spring
22	44735						X	X	Retaining ring
23	37262	X	X				X	X	Disc follower
24	422426	X	X				X	X	Disc follower stud
25	37276	X	X				X	X	Disc follower washer
26	44371	X	X				X	X	Retaining ring
27	422434						X	X	Disc follower stud cpl.
28	507063	X	X						Retaining ring
29	53641	X	X						Nut
30	422081	X	X						Disc follower disengaging lever
31	44419	X	X						Disc follower positioning spring
32	44471	X	X						Screw stud (eccentric)
33	353183	X	X						Disc selector cam slide
34	141786	X	X						Hinge screw
35	49204	X	X						Friction washer
36	422016	X	X						Disc selector lever
37	37244	X	X						Disc selector control lever knob spring clip
38	421883-452	X	X						Disc selector control lever knob( <u>Plastic colour</u> )

# 6

# 6100 series

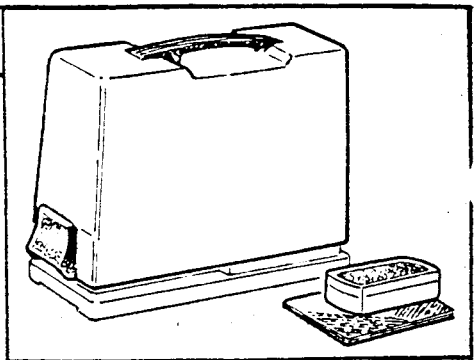

8-9-10-12  
13-14-15-16 } 1  
17-18-19

8-9-11  
12-13-  
14-15-16  
17-18-20 } 4

8-9-11-13  
14-15-16-17 } 2  
18-19

8-9-11-12  
13-14-15-16  
17-18-19 } 5

8-9-11-13  
14-15-16-17 } 3  
18-19

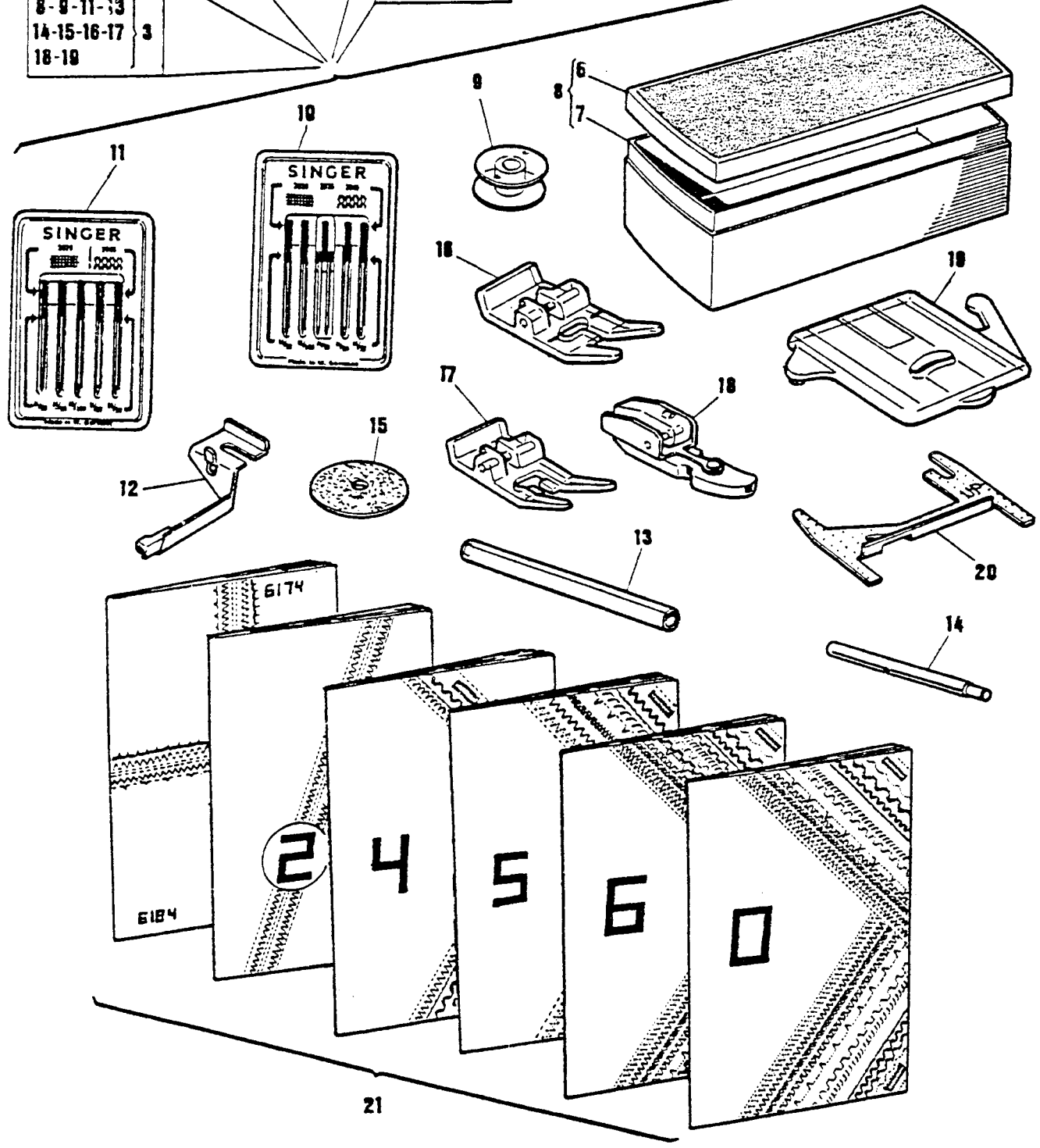

From the library of: Diamond Needle Corp

## LIST OF PARTS FOR MACHINES 6100 SERIES

REF. N.	PART. N.	6174	6184	6100	6106	6105	6104	6102	PART DESCRIPTION
1	422026			X	X	X			Attachment set cpl.
2	422027						X		Attachment set cpl.
3	422028							X	Attachment set cpl.
4	422026-451	X							Attachment set cpl.
5	422026-453		X						Attachment set cpl.
6	421743-451	X	X	X	X	X	X	X	Attachment box cover
7	421744-451	X	X	X	X	X	X	X	Attachment box base
8	421742-451	X	X	X	X	X	X	X	Attachment box
9	172336	X	X	X	X	X	X	X	Bobbin Transparent plastic (2)
10	381275			X	X	X			Needle pack (Plastic) Containing : cat. 2020; size 11, 14 and 16 cat. 2045; size 14 cat. 2025; size 14
11	103489	X	X				X	X	Needle pack (Plastic) Containing : cat. 2020; size 11, 14, 16 cat. 2045; size 14 (2)
12	381213	X	X	X	X	X			Blindstich guide
13	311800			X	X	X			Spool pin adaptor (2)
	311800	X	X	X	X	X	X	X	Spool pin adaptor (1)
14	173571	X	X	X	X	X			Spool pin (2)
	173571	X	X	X	X	X	X	X	Spool pin (1)
15	8879-454			X	X	X			Spool pin felt (2)
	8879-454	X	X				X	X	Spool pin felt (1)
16	161927	X	X	X	X	X	X		Snap-on buttonhole foot
17	171498	X	X	X	X	X	X	X	Snap-on special purpose foot
18	507836	X	X	X	X	X	X	X	Snap-on zipper foot
19	381459		X	X	X	X	X	X	Snap-in feed cover plate
20	161894	X							Needle plate raising plate (Shim)
21	Form n°								See table below

## 21) INSTRUCTION BOOKS : Languages - Form N.

Model	Italian	English	German	French	Dutch	Danish	Finnish	Swedish	Spanish	English U. S.
6102	920	921	922	923	924	925	926	927		928
6104	940	941	942	943	944	945	946	947		948
6105	950	951	952	953	954	955	956			958
6106	960	961	962	963	964	965	966	967		968
6100	744	751	752	753	754	755	747	748		
6136	970	971	972	973	974	975	976	977		978
6110										902
6174/6184	982	982	982	983	984	985	985	985		

6

# 6100 series

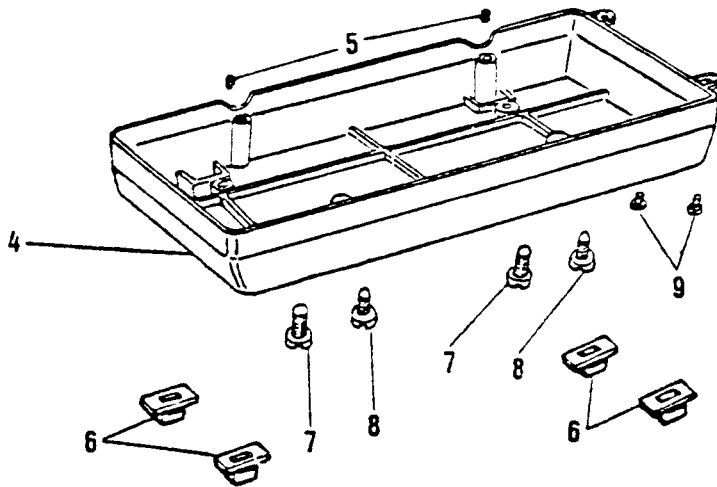
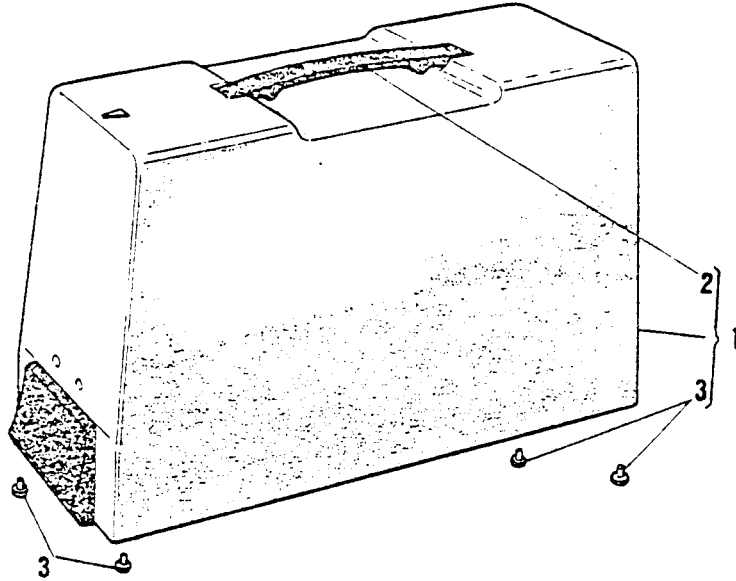
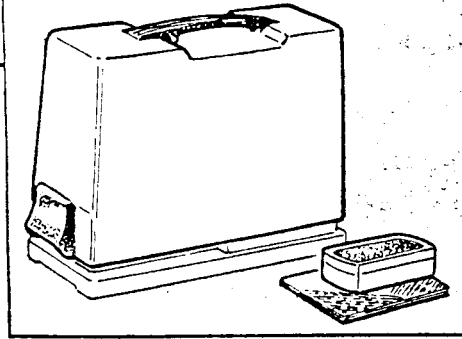

From the library of: Diamond Needle Corp

LIST OF PARTS FOR MACHINES 6100 SERIES

REF. N.	PART. N.	6174	6184	6100	6106	6105	6104	6102	PART DESCRIPTION
1	421712-451	X	X	X	X	X	X	X	Light screw
2	421967	X	X	X	X	X	X	X	Heat sink
3	194120-015	X	X	X	X	X	X	X	Bulb 15 W - 220 V
	194120-016	X	X	X	X	X	X	X	Bulb 15 W - 120 V
	194120-017	X	X	X	X	X	X	X	Bulb 15 W - 240 V
4	988138-001	X	X	X	X				Motor cpl. 220 V (for 6136-6146-6156-6120-6130 Models)
	988138-002	X	X	X	X				Motor cpl. 240V (for 6136-6146-6156-6120-6130 Models)
	988138-007	X	X	X	X				Motor cpl. 120 V (for 6136-6146-6156-6120-6130 Models) Canada
	988138-020	X	X	X	X				Motor cpl. 120 V (for 6136-6156-6146-6120-6130 Models) Usa
	605079-027				X	X	X	X	Motor cpl. 220 V
	605079-029				X	X	X	X	Motor cpl. 240 V
	605079-028				X	X	X	X	Motor cpl. 120 V (CANADA)
	605079-051				X	X	X	X	Motor cpl. 120 V (USA)
5●	604016-001	X	X	X	X	X	X	X	Screw
6●	988136-001	X	X	X	X	X	X	X	Dust cover
7	605209-016	X	X	X	X				Light cpl. 220/240 V (for 6136-6146-6156-6120-6130 Models)
	605209-020	X	X	X	X				Light cpl. (Canada) (for 6136-6146-6156-6120-6130 Models)
	605209-037	X	X	X	X				Light cpl. (Usa) (for 6136-6146-6156-6120-6130 Models)
	605209-012				X	X	X	X	Light cpl. 220/240 V
	605209-011				X	X	X	X	Light cpl. (CANADA)
	605209-036				X	X	X	X	Light cpl. 120 V (USA)
8●	619436-001	X	X	X	X	X	X	X	Brush spring (2)
9●	619435-004	X	X	X	X	X	X	X	Brush (2)
10●	603985-013	X	X	X	X				Switch cpl. (for 6136-6146-6156-6120-6130 Models)
	603985-016	X	X	X	X				Switch cpl. (CANADA) (for 6136-6146-6156-6120-6130 Models)
	603985-031	X	X	X	X				Switch cpl. (USA) (for 6136-6146-6156-6120-6130 Models)
	603985-019				X	X	X	X	Switch cpl. 220/240 V
	603985-018				X	X	X	X	Switch cpl. 120 V (CANADA)
	603985-030				X	X	X	X	Switch cpl. 120 V (USA)
11●	988140-001				X	X	X	X	End housing
	988140-002	X	X	X	X	X	X	X	End housing (for 6136-6146-6156-6120-6130 Models)
12●	603907-001	X	X	X	X	X	X	X	Nut
13●	604233-001	X	X	X	X	X	X	X	Mounting bracket
14●	603956-001	X	X	X	X	X	X	X	Tapping screw (2)
15●	988176-001	X	X	X	X	X	X	X	Pulley
16	604018-002	X	X	X	X	X	X	X	Washer
17	604020-001	X	X	X	X	X	X	X	Screw
18	352745	X	X	X	X	X	X	X	Clip
19	604102-001	X	X	X	X	X	X	X	Switch enclosure
20	514732-451	X	X	X	X	X	X	X	Nut
21	514731-451	X	X	X	X	X	X	X	Set screw
22	352449		X	X	X	X	X	X	Screw (1)
	352449	X							Screw (2)
23	352584-452	X							Grommet
24●	988275-021	X	X	X	X				Foot controller 220 V (for 6136-6146-6156-6120-6130 Models)
	988275-024	X	X	X	X				Foot controller 240 V - GB (for 6136-6146-6156-6120-6130 Models)
	988275-029	X	X	X	X				Foot controller 120 V - CANADA (for 6136-6146-6156-6120-6130 Models)
	988275-026	X	X	X	X				Foot controller 240 - AUSTRALIA (for 6136-6146-6156-6120-6130 Models)
	988275-027	X	X	X	X				Foot controller 120 - USA (for 6136-6146-6156-6120-6130 Models)
	988274-051				X	X	X	X	Foot controller 220 V
	988274-055				X	X	X	X	Foot controller 240 V (GB)
	988274-064				X	X	X	X	Foot controller 120 V (CANADA)
	988274-062				X	X	X	X	Foot controller 120 V (USA)
	988274-057				X	X	X	X	Foot controller 240 V (AUSTRALIA)
25●	604654-010	X	X	X	X				Cord cpl. 220 V (for 6136-6146-6156-6120-6130 Models)
	604654-016	X	X	X	X				Cord cpl. 120 V Canada (for 6136-6146-6156-6120-6130 Models)
	604654-011	X	X	X	X				Cord cpl. 240 V - GB (for 6136-6146-6156-6120-6130 Models)
	604654-014	X	X	X	X				Cord cpl. 120 V - USA (for 6136-6146-6156-6120-6130 Models)
	604874-025				X	X	X	X	Cord cpl. 220 V
	604874-023				X	X	X	X	Cord cpl. 120 V - CANADA
	604874-017				X	X	X	X	Cord cpl. 240 V - GB
	604874-021				X	X	X	X	Cord cpl. 120 V - USA NLA
26	604136-009	X	X	X	X	X	X	X	Motor belt

● Parts to be ordered directly from Bonniers

From the library of: Diamond Needle Corp

## MARKETING TERRITORIES (Territory Code)

### A (105/115V · 220/240V.)

Aden  
Algeria  
Angola  
Bahrain  
Bangladesh  
Benin (Danomey)  
Burma  
Burundi  
Cambodia  
Cameroon  
Cent. Africa Empire  
Chad  
Congo (Brazzaville)  
Egyptian Arab Republic  
Ethiopia  
Fiji Islands  
Gabon  
Gambia  
Ghana  
Guam  
Guinea  
Guyana  
High Volta  
Hong Kong  
India  
Indonesia  
Iran  
Iraq  
Ivory Coast  
Jordan  
Kenya  
Kuwait  
Laos  
La Reunion  
Lebanon  
Liberia  
Libya  
Malagasy Rep.  
Malawi  
Malaysia  
Mali  
Mauritania  
Mauritius  
Morocco  
Mozambique  
Niger Repub.  
Nigeria  
North Yemen  
Pakistan  
Rhodesia  
Saudi Arabia  
Senegal  
Sierra Leone  
Singapore  
South Korea  
South Yemen  
Sri Lanka  
Sudan  
Syria  
Taiwan  
Tangiers  
Tanzania  
Thailand

Togo  
Tunisia  
Uganda  
Upper Volta  
Vietnam  
Zaire (Kinshasa)  
Zambia

### B (220V)

South Africa

### C (220 or 240V)

New Zealand

### D (240V)

Great Britain  
(England, Scotland,  
Wales).  
Malta

### E (220V)

Netherlands

### F (220V)

Austria  
Belgium  
Denmark  
Finland  
Greece  
Italy  
Switzerland  
W. Germany

### G (120V)

Canada  
United States

### H (120V + 220V)

Argentina  
Bahamas  
Barbados  
Bermuda  
Bolivia  
Brazil  
British Honduras  
Canal Zone  
Chile  
Colombia  
Costa Rica  
Ecuador  
El Salvador  
French West Indies  
Guatemala  
Honduras Republic  
Jamaica  
Mexico  
Neth. Antilles

Nicaragua  
Panama  
Paraguay  
Peru  
Philippines  
Puerto Rico  
Surinam  
Trinidad & Tobago  
Venezuela  
Virgin Islands  
West Indies  
(Antigua, Dominica,  
Grenada, Montserrat,  
St. Christopher, Nevis  
Anguilla, St. Lucia,  
St. Vincent, St. Kitts).

### J 127/220V)

Belgium Bi-Volt  
W. Germany Bi-Volt

### K (240V)

Australia

### L (220V)

Norway

### M (105V)

Japan

### N 127/220V)

France Bi-Volt  
Non mandatory  
countries Bi-Volt.

### O Canada (120V)

### P (220V)

Albania  
France  
Gibraltar  
Iceland  
Israel  
Jugoslavia  
Luxembourg  
Monaco  
Portugal  
Spain  
Turkey

### Q (240V)

Cyprus

### R (220V)

Sweden

### S (220V)

Eire

## LIST OF PARTS FOR MACHINES 6100 SERIES

REF. N.	PART. N.	6174	6184	6100	6106	6105	6104	6102	PART DESCRIPTION
1	148817		X	X	X	X	X	X	Carrying case cpl.
2 •	148811-004		X	X	X	X	X	X	Carrying case handle
3 •	148815-451		X	X	X	X	X	X	Carrying case cushion (4)
4	422479-452	X							Bed cover (bottom)
5	141925	X							Machine hinge connection set screw
6	422490 -	X							Bed leg cushion
7	354675	X							Screw (2)
8	422483	X							Screw (2)
9	139986	X							Screw (2)

• Parts to be ordered directly from Bonnieres



# 7

# 6100 series

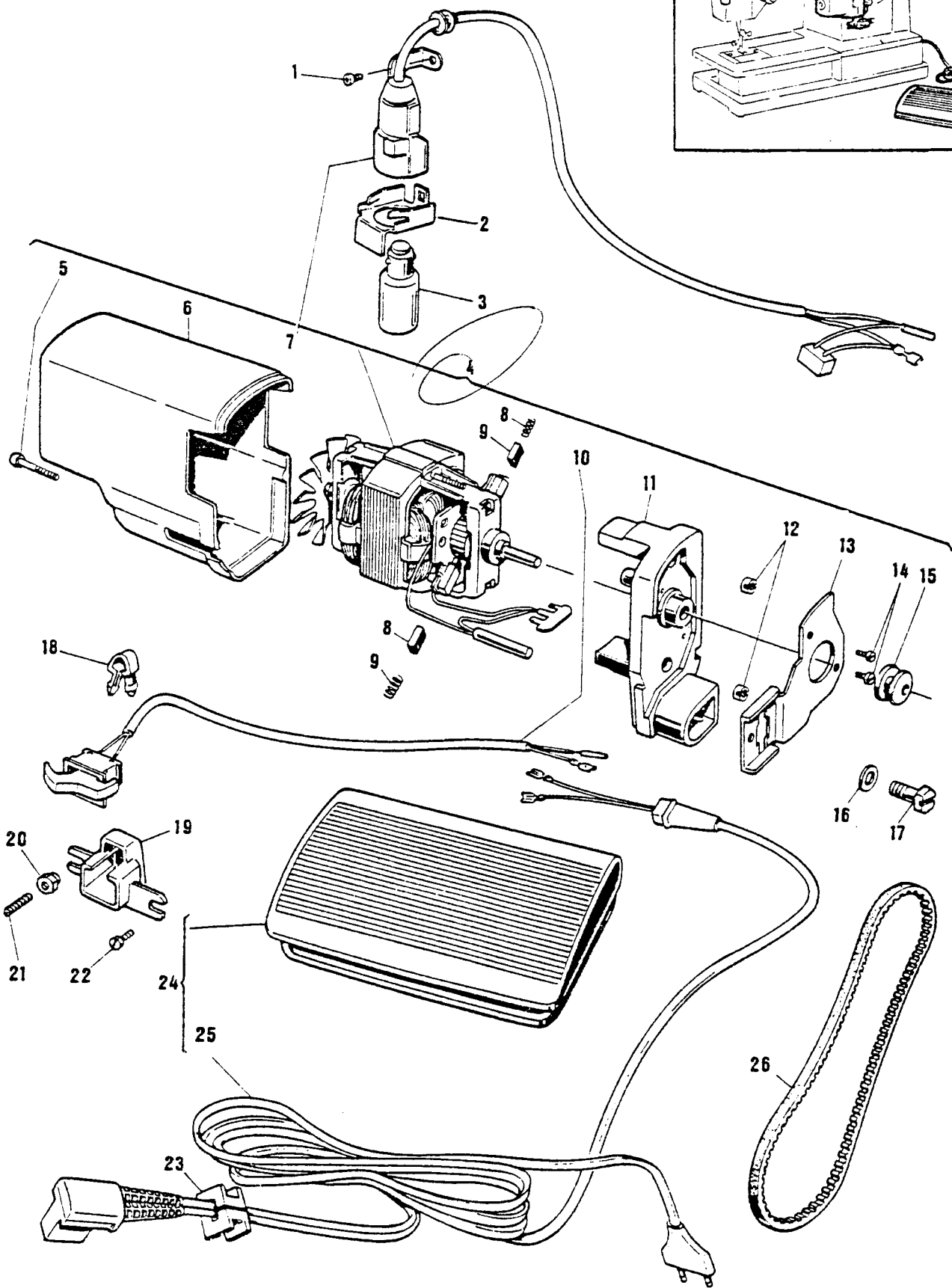
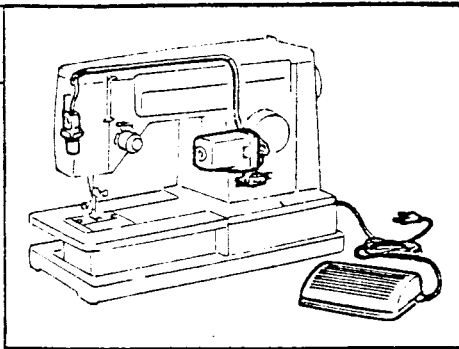

From the library of: Diamond Needle Corp